



SIEMENS DIGITAL INDUSTRIES SOFTWARE

# What's new in Solid Edge 2022

Engineered to grow your business

Working in partnership with our customers, we've added more than 500 enhancements to Solid Edge 2022 – supporting modern product development processes, allowing you to do more with your resources and enabling new ways of working.

“Solid Edge 2022 rocks! It's full of enhancements and new functionalities that make everyday work faster and easier. Siemens continues to listen to our requests and deliver game-changing software.”

Michel Corriveau  
Veteran Solid Edge User

**SIEMENS**

[siemens.com/solidedge2022](https://www.siemens.com/solidedge2022)

**Create new design iterations at a click of a button.**

Automatically generate new designs based on defined parameters and rules with the embedded Solid Edge® Design Configurator software. Solid Edge Design Configurator is a design automation application that adds rule-based automation to a user's familiar Solid Edge mechanical design environment. Completely embedded in Solid Edge, it enables the quick customization of products based on design parameters and rules. Rule-based automation can boost productivity and design speed.

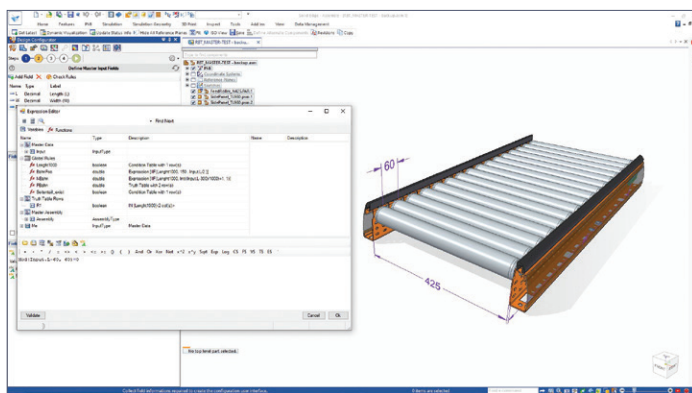

**Seamlessly integrate computer-aided design (CAD) geometry.**

CAD Direct, a new built-in 3D design capability, improves productivity when working with geometry from popular CAD systems. Insert files directly into a Solid Edge assembly without the need to translate the file separately, maintaining associativity. Data is stored in the 3D design assembly file, preventing data duplication and allowing the inserted geometry to be used for downstream design work.

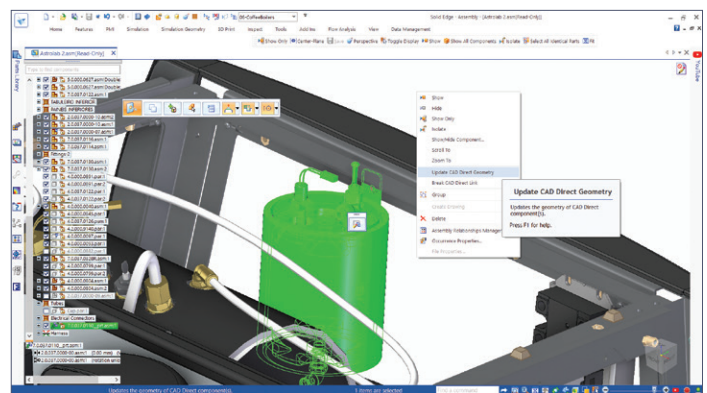

**Experience 2.5 axis milling – now included in Solid Edge mechanical design.**

Solid Edge Classic, Foundation and Premium now include fully functional 2.5-axis milling capabilities for customers with active maintenance. Fully integrated with Solid Edge, Solid Edge CAM Pro 2.5 Axis allows users to maintain full associativity with design data while instilling confidence with automated tool path creation and visualizations for optimized machining processes.

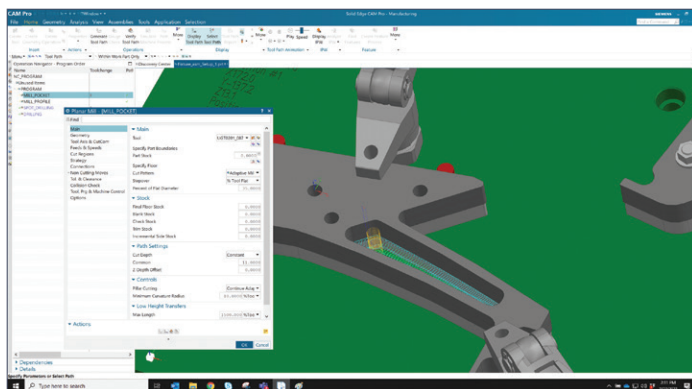

**Collaborate with colleagues, partners and customers.**

Xcelerator Share, the next-generation, cloud-based collaboration solution from Siemens Digital Industries Software, uses design-centric tools such as 3D and 2D CAD view and markup, augmented reality (AR), virtual prototyping, secure project-based sharing and more. Work from anywhere – home, office or in transit – with browser-based access. No additional information technology (IT) infrastructure is required.

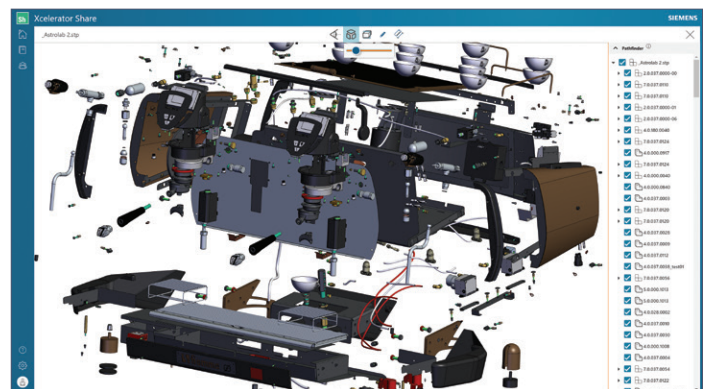

**Visualize designs in the context of real-world environments.**

Full-color point cloud visualization for assemblies provides the confidence you need to position new design equipment in any setting, which is especially useful when retrofitting factories or plants. Solid Edge assembly measurement and viewing tools can be used to position and design equipment in the context of the point clouds.

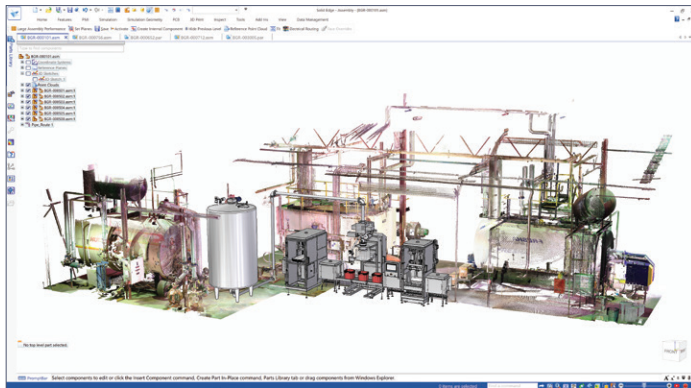

**Leverage b-rep and mesh geometries in the same model without conversions.**

Unique hybrid model capabilities allow b-rep and mesh geometries to coexist in the same model for downstream assembly use, speeding workflows and making mesh models even more useful. Removing the need to convert mesh or b-rep geometry for them to work together reduces model development time.



**Don't let complex assemblies slow you down.**

Solid Edge puts you at the top of your game with orders-of-magnitude performance improvement in large assembly modeling for the third straight year. Fast assembly open allows users to enter a preview mode in order to reduce the amount of data that is loaded. Multi-body assembly modeling mode is a new environment to model internal components within an assembly file. New component finder puts intuitive search of assembly components at your fingertips with auto-complete suggestive filters.

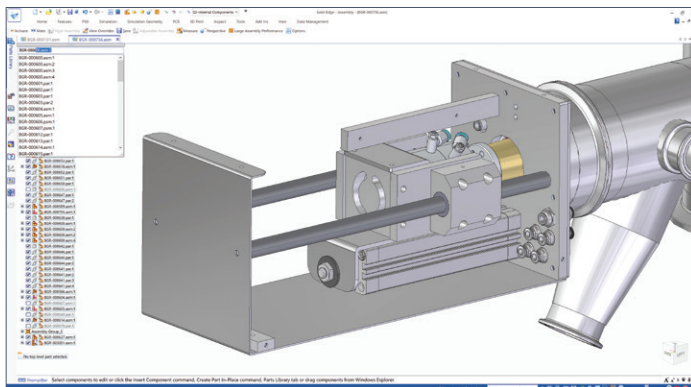

**Reinvent the wheel effortlessly.**

Solid Edge introduces an industry-unique radiate command enabling effortless editing of the radii of circles in part models. This productivity enhancement allows you to simultaneously edit the diameter of existing circular geometry. Based on synchronous technology, this capability allows satellite faces to move radially as an operation is performed while maintaining design intent. Pattern faces are automatically found and edited. Pattern locked dimensions are relaxed during radiate and locked back when the operation is finished.

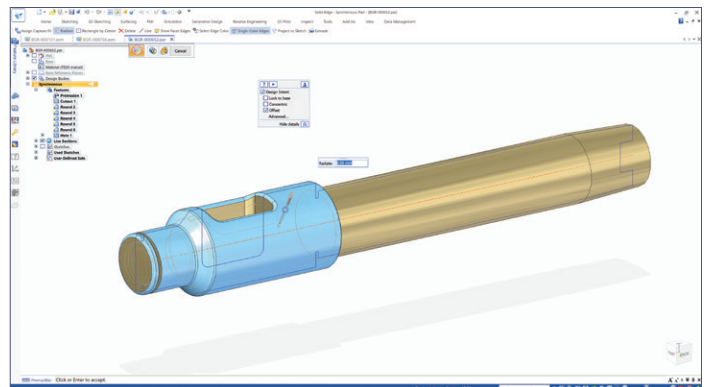

**Accelerate the speed of simulation.**

New automated mesh generation processes in Solid Edge Simulation provide high-quality mesh with minimum effort, controlling mesh without the need for parameters. Simulation display performance, now up to 10x faster than before, optimizes load times for results data. Satisfy increasing demands for high performance and efficiency of hydraulic systems with a new hydrostatic pressure load type that determines the maximum and minimum pressure that is exerted by a fluid at equilibrium due to the effect of gravity.

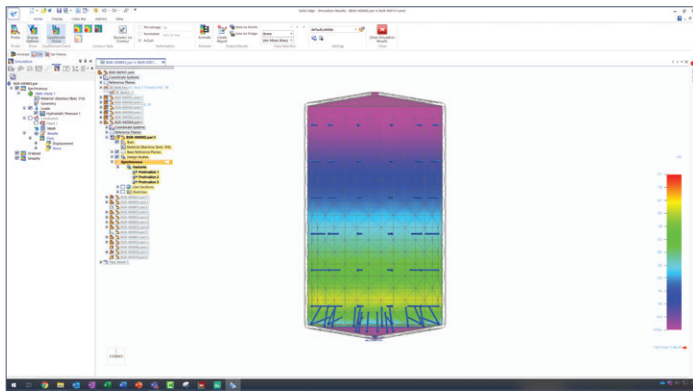

**Improve the flow of piping systems design.**

Introducing Simcenter™ Flomaster™ for Solid Edge software. Based on a leading 1D computational fluid dynamics (CFD) simulation tool for fluids engineering, this new product allows users to easily model and analyze the fluid and thermal flows in their piping systems. It automatically extracts 3D geometries to generate system-level models, which cuts the time required to build a simulation model by up to 90 percent. With built-in wizards, Simcenter Flomaster for Solid Edge is easy for novices to use, yet it is also appropriate for simulation experts with its advanced capabilities such as simulation of rapid dynamic events and pressure surge.

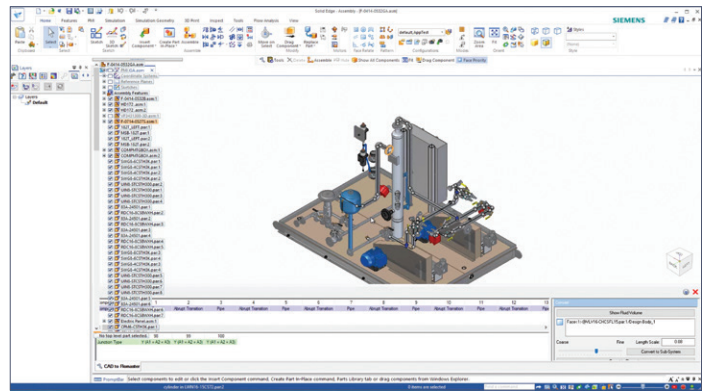

**Generate a clear view of your design data.**

New built-in customized reports for Solid Edge, dynamic visualization, provides dynamic methods for viewing and sorting assembly parts and components. The visual reports are built on rules that are easily created with filters that resemble Excel spreadsheet software within interactive tables.

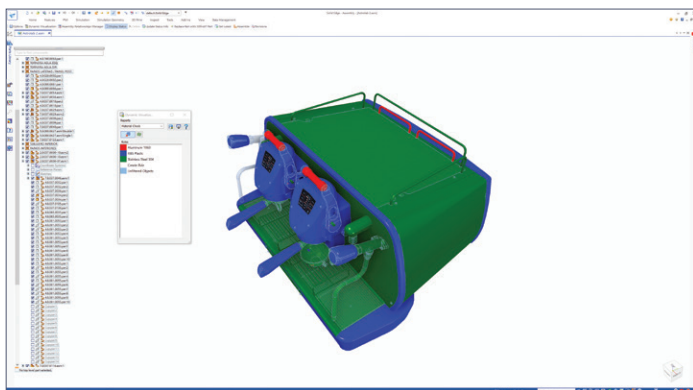

Other usability enhancements to Solid Edge 3D Design include:

- Assign capture fit – Predefines relationships in the part environment for consumption in the assembly environment, allowing users to intelligently assemble commonly used parts faster and with less effort
- Subdivision modeling capabilities – Subdivision bridge allows for the easy creation of different types of bridges. Offset is useful for dividing faces without the need for extensive cage splitting. Align to curve moves cage vertices to match existing shapes or to design new shapes using hand-drawn curves. Lift support for laminar edges creates new faces when laminar edges are lifted
- Gussets – No more building gussets by hand. Create gusset plates as internal components on both assembly components and frames
- Family of assemblies (FOA) – Visual indication for out-of-date FOA members
- Match coordinate systems – Faster creation of these systems as a single relationship
- Equation-driven curves – Adds additional predefined curves; provides dynamic preview of curve as equations and parameters change
- Wrapping decals – Decals may be passed to KeyShot for rendering

2D drafting and design enhancements include:

- Watermarks on draft – Easily add and manage watermarks in your drawings
- Property text in tables
- Dimensions to virtual intersections
- Open model from parts list – Works for parts list and family of assemblies parts list
- Family of assemblies' draft table
- Coordinate dimension support for 2D translator provides import and export of .dwg and .dxf files
- Multi-core drawing view update for section views, auxiliary views – helps users quickly update large drawings that contain principal as well as derived drawing views

### Extending value

The Solid Edge portfolio is an integrated set of powerful, comprehensive and accessible tools that advance all aspects of the product development process. Solid Edge addresses today's complexity challenges with automated digital solutions that cultivate creativity and collaboration.

By harnessing the latest innovative technologies in mechanical and electrical design, simulation, manufacturing, publications, data management and cloud-based collaboration, using Solid Edge dramatically shortens time-to-market, provides greater production flexibility and significantly reduces costs with its collaborative and scalable solutions.

Solid Edge, which is part of the Xcelerator™ portfolio, the comprehensive and integrated portfolio of software and services from Siemens Digital Industries Software, provides an innovative and comprehensive approach to product development for the mainstream market.

For more information, visit [www.siemens.com/solidedge2022](http://www.siemens.com/solidedge2022).

**Siemens Digital  
Industries Software**  
[siemens.com/software](http://siemens.com/software)

Americas  
1 800 498 5351

Europe  
00 800 70002222

Asia-Pacific  
001 800 03061910

For additional numbers,  
click [here](#).