



SIEMENS



GEOMETRIC  
SOLUTIONS

Siemens PLM Software

## NX CAD/CAM Turning Foundation

### Benefits

- Automated feature handling speeds common processes
- Boundary-based cutting provides flexibility to cut on minimal geometry
- Solids-based cutting cuts complex shapes intelligently
- Master model capability ensures that NC development stays associative to the source model
- Model Edit capabilities make it easy to adjust model for optimal NC programming
- Full design capability is provided with integrated CAD/CAM seat

### Summary

NX™ CAD/CAM Turning Foundation facilitates NC programming of turning tool paths in an integrated CAD environment. All of the supporting functions for NC programming are provided, from translators to tool path visualization to postprocessing.

### Turning

NX provides comprehensive turning functionality driven by the in-process 3D solid part model.

### Associative turning profile

The software tracks allowable turning volumes precisely, even for mill-turn parts. You can maintain correct turning profiles through part updates. Spun solid profiles and merged multiple cross sections provide the correct turning profiles for any part and automatically update when geometry changes.

### Comprehensive set of automatic operations

You can easily program a full range of lathe operations, including:

- On-center hole making: spot, drill, peck, chip, ream and tap
- Roughing: face, turn, back turn, bore, back bore and undercut – all with multiple patterns and depth of cut control and angle control
- Rough/finish grooving – with auto left/right tracking point control
- OD/ID threading
- OD/ID face
- Cutoff operation and bar feed operation types
- Part-off operation with preplunging and chamfering options

### Feature automation

NX Turning automates grooving with feature-based machining processes. You can produce threads according to standards with parameter-driven thread cutting processes. You can also break corners with arcs or chamfers that account for the finish status of the adjacent geometry.

# NX CAD/CAM Turning Foundation

## Benefits *continued*

- Our integrated postprocessor and Post Builder provide production-ready output
- All supporting functions are provided

## Features

- Synchronous technology
- 2D drafting
- Solid modeling
- Basic surface modeling
- Sheet metal modeling
- Wizard builder
- Postprocessing and Post Builder
- Shop documentation

## User control

You can customize and fine tune turning boundaries to account for various finish requirements or in-process characteristics, such as grind stock. NX suppresses features as needed. Transitions to/from boundary edits ensure that the desired end result is easily achieved. Additionally, you can compensate for cutter diameter variance or use zero diameter tool programming (part dimension programming).

## Advanced options

NX provides special cutting patterns, such as finish all, down-only cutting and toward/away from corner patterns. You can protect valuable work pieces by interrupting long cuts for insert changes. Safe exit and reentry to the cut are handled automatically.

## Teach mode

NX Turning provides step-by-step motion instructions through a few simple mouse clicks. It supports all of your turning center's capabilities (including bar feeds or tail stocks) and visualizes their motion.

## Tools

You can specify the holder and insert as part of a tool assembly. NX enables you to

configure left-handed or right-handed tools for inside or outside diameters. You can cut either side of the centerline using upper or lower turret configurations. Multiple drive points per tool facilitate flexible usage of tools vs various geometry. Probing tools are available for on-machine probing cycles.

## Standard supporting functions

### Translators

You can read data from practically any CAD system with a set of translators for the Parasolid® software, IGES, DXF and STEP and JT™ formats. In addition you can write data in all of these formats, plus STL.

### Operation navigator

From the CAM application's information center, you can create, view, modify, verify, inspect and organize your NC programs. You can manage tools, methods, geometry and output from an information-rich program display.

### Tool path visualization

You can stay confident with tool path visualization and material removal verification tools. Integrated collision checking identifies any possible problems.

### Tool path editing

You can make fast changes to tool path results with graphical editing tools and protect your edits by locking tool paths from future recalculations.

### NC wizards

With the NC Wizard Builder, you can create semi-automated processes customized to your environment. Highly familiar wizard presentations enable you to streamline common tasks with minimum user input.

### Postprocessing

The Turning Foundation outputs production-ready g-code with integrated postprocessing. You can edit and fine tune existing postprocessors with our included interactive Post Builder application or even build a postprocessor from scratch using Post Builder templates. In addition, you can use included sample posts or download a post from our support library.

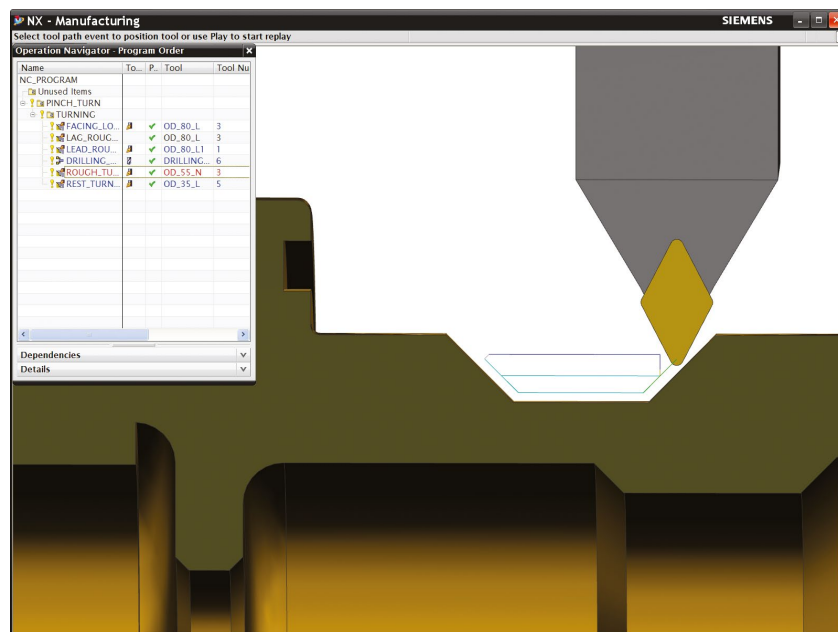

### Shop documentation

You can produce html setup documents with the included shop doc capability.

### Feed rate optimization

NX CAM helps you to easily maximize material removal rates and minimize tool wear. The ability to adjust feed rates to achieve a specified chip volume eliminates overloading as well as under-utilization of the cutting tool.

### Assembly modeling

NX CAM includes important fixture components in the programming session and facilitates intelligent collision avoidance. Our master model concept keeps the assemblies and tool paths associative to your source model. NX assembly design supports “top-down” and “bottom-up” approaches and provides rapid navigation of the assembly hierarchy with direct access to the design model of any component or subassembly.

### Standard model editing functions

NX CAM provides geometry tools to support common model editing functions that make NC programming more efficient. The standard range of functions provided are effective for making the kinds of changes to existing models that are sometimes needed in the NC programming context, such as altering a basic stock material shape. Using the standard model editing functions, you can perform important model cleanup tasks with key editing capabilities for:

#### Associative geometry

You can associate copies of master geometry, enabling model editing without affecting the original design model.

#### 3D wireframe construction for boundaries

Wireframe elements can be constructed from scratch or derived from part edges. Boundaries can be used directly for certain 2D operation types or used indirectly as containment boundaries to control tool path coverage.

#### Basic solid shapes

Solid blocks and cylinders can be created for use as blank models or fixture components.

#### Surface extensions and patches

You can patch over features that don't need to be machined. Tool paths will move smoothly across the patch, rather than trying to dig into the feature. You can extend faces to help guide tool tips around 3D edges if necessary.

#### Surface and edge extraction

Surfaces and edges can be extracted, divided, projected and used in various ways to more precisely support the needs of NC operations. For example, a divided surface provides an

additional edge that can be used to drive or define tool paths. Likewise, trim, sew and join functions enable surface and edges to be modified to support NC operations.

### Synchronous modeling

Synchronous modeling, a powerful method for directly editing solid faces, is also available in the NC environment. Developing as-cast models or other derivatives from the existing parts is easy since the programmer simply needs to push and pull on the existing faces.

### Extended CAD content (included with the CAD/CAM package)

The standard CAM version of the CAD/CAM package provides geometry tools to support common model editing functions. A set of more extensive CAD functions (described below) are available in the CAD/CAM version of this package that enable you to create and edit complex 3D part models and produce drawings. The combination of CAD and CAM in one system provides one of the most fully integrated solid modeling systems available today.

### Drafting

You can create engineering drawings that remain associative to your part models, including automatic view creation from solids, hidden line processing and automated parts lists. You can use templates to automatically create drawings for borders and view layouts.

### Solid modeling

Using the Turning Foundation, you can develop 3D models with a full range of synchronous modeling and parametric modeling tools, including wireframe, primitives, swept and revolved bodies. Boolean operations and associative editing are supported. You can provide details such as blends, tapers and thin-wall features. NX modeling is powered by synchronous technology, Siemens PLM Software's unique approach to 3D design that combines the power of parametric feature-based modeling with the freedom of history-free modeling.

### User-defined features

The Turning Foundation lets you capture and store families of features for easy retrieval and editing, starting with existing associative solid models. You can establish relationships between parameters, define feature variables, set default values and decide the general form the feature will take when started.

### Sheet metal

With the Turning Foundation, you can create sheet metal component models using feature-based design tools for tabs, flanges and other typical features. You can use

forming tables and bend sequence tables to account for bend deformation and generate accurate flat pattern data for manufacturing.

#### Associativity

The Turning Foundation absorbs changes with ease with a fully integrated CAD/CAM system that keeps the NC program connected to the design model and updates to new geometry.

#### Available add-ons

You can configure the perfect CAM seat by adding the tool path creation options that your programs require. You can choose from:

- Wire EDM
- 2.5-Axis Milling
- 3-Axis Milling
- 5-Axis Milling
- Turbomachinery Milling
- Machine Simulation
- Feature-Based Machining Author

#### Available Teamcenter integration

You can integrate your NX Mach CAM package with Teamcenter® software by including the NX CAM Teamcenter Client add-on. This Mach-level integration provides a managed environment for your NX data. Additional Teamcenter functionality is available separately.

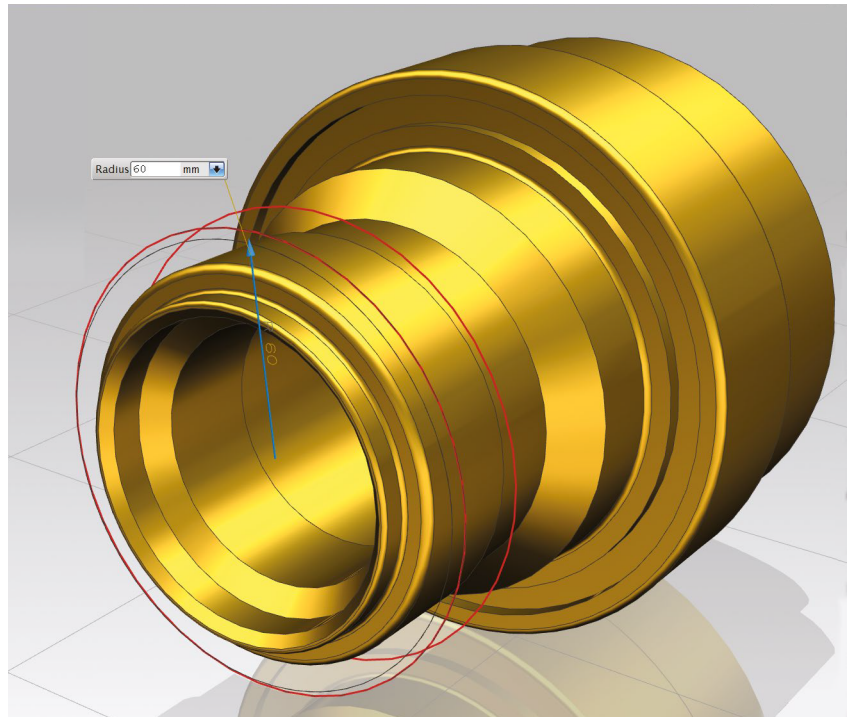

#### Contact

Siemens PLM Software

Americas +1 314 264 8499

Europe +44 (0) 1276 413200

Asia-Pacific +852 2230 3308

[www.siemens.com/plm](http://www.siemens.com/plm)

© 2015 Siemens Product Lifecycle Management Software Inc. Siemens and the Siemens logo are registered trademarks of Siemens AG. D-Cubed, Femap, Fibersim, Geolus, GO PLM, I-deas, JT, NX, Parasolid, Solid Edge, Syncrofit, Teamcenter and Tecnomatix are trademarks or registered trademarks of Siemens Product Lifecycle Management Software Inc. or its subsidiaries in the United States and in other countries. All other logos, trademarks, registered trademarks or service marks belong to their respective holders.  
23144-Y6 5/15 B



844-GEO-SUPT  
support@geopl.com  
geopl.com