

SIEMENS



GEOMETRIC
SOLUTIONS



Siemens PLM Software

NX CAE

Advanced simulation solutions to drive smarter product decisions

[siemens.com/plm/nxcae](https://www.siemens.com/plm/nxcae)

Simulation challenges

“Of the total time needed by engineers to create a simulation for a system or subsystem, 80 percent is devoted to generating a model.”

Autosim Consortium

“So it isn’t the threat of a 6-hour solver run that’s holding you up; it’s how you are going to produce the geometric and finite element models fast enough that the 6-hour run does become the gating factor. If it takes you 6 weeks to prepare the input, the 6-hour run time is irrelevant.”

Aerospace executive

Siemens understands your simulation challenges

Industry pressure to decrease development time and improve quality is driving increased use of simulation throughout the product lifecycle. But are your simulation results available quickly enough to impact critical design decisions?

Simulation results are too late

Business leaders often complain that computer aided engineering (CAE) takes too long, and results usually come back too late or are out of synch with the latest design iteration. As a result, design changes based on simulation results usually lead to expensive post-design change orders.

Difficulty in simulating real-world conditions

To simulate real-world conditions, analysts must consider the impact from a number of different physics such as dynamics, thermodynamics, fluid flow, nonlinear material behavior and motion. Usually, effects from one physics domain also impact how a product behaves in another physics domain. Understanding this multi-physics behavior is a major challenge to accurately predicting product performance.

Complex processes and disconnected tools

Simulation tools today tend to be specific to a certain analysis domain. As a result, analysts are required to learn a multitude of different tools and user interfaces. In addition, each of these tools uses disparate input and output files that ultimately hinder an analyst’s ability to perform multi-physics simulation efficiently and accurately. Using a number of disconnected tools also makes it difficult to conduct trade-off analyses because model preparation and management work becomes too large for an engineer to manage.

Loss of simulation knowledge and understanding of past decisions

Much of a company’s simulation experience and knowledge is trapped in the heads of its analysts. As analysts retire or leave the company, that experience and knowledge are lost along with the analyst. In addition, simulation data is not managed in the same methodical manner as product design data. Simulation data often resides in folders within the analyst’s hard drive. Only the analyst knows which file is the latest version and what assumptions and decisions were made for each simulation.

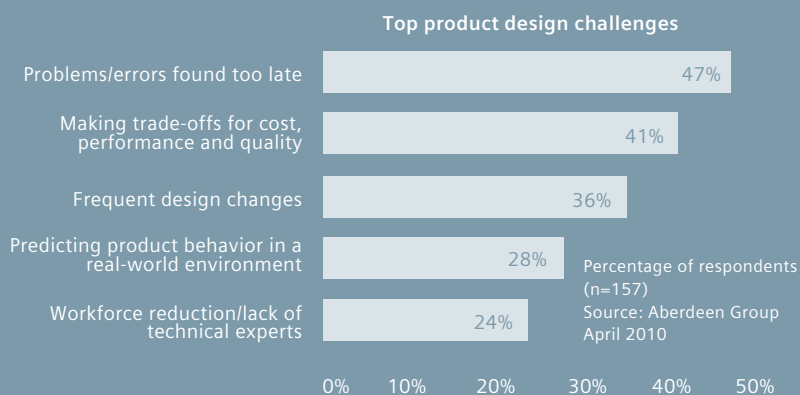

NX CAE advantage

Siemens' CAE vision and heritage

Our vision is to deliver engineering simulation solutions that drive product performance decisions across the complete product lifecycle.

Siemens PLM Software executes this vision by building upon our simulation heritage which spans over 40 years and encompasses well known CAE brands like Nastran, SDRC I-deas®. Siemens has strengthened and expanded upon the technologies from its long simulation legacy and has brought them together to form NX™ CAE software.

A modern CAE environment

NX CAE directly addresses the challenges you face with simulation today through a modern and completely integrated environment that delivers significant benefits. NX CAE does not require NX CAD and can be used as a standalone pre/postprocessor with support for multi-CAD geometry. NX CAE delivers additional benefits when used in situations where NX is used for design, such as seamless data transfer between the design team and analysis team.

Speed simulation processes by up to 70 percent

Increasing simulation productivity speeds your entire product development cycle so you can bring your products to market faster. More efficient simulation processes also lead to more innovation by allowing more design-analysis iterations that can be used to test more design alternatives and make critical design decisions earlier.

Increase product quality

By more easily simulating real-world conditions, you get a truer understanding of how your product will perform. NX CAE also facilitates easier trade-off analysis across multiple disciplines so you develop more robust products. Requirements tracking and reporting capabilities allow you to quickly gauge if your product is performing to specification

Lower overall product development costs

Faster simulation processes means analysis results are fed back to design earlier, leading to reduction in costly, late design change orders. Additionally, correlating simulation with physical testing provides more confidence in your analysis result so you reduce costly physical prototypes.

Foundation for simulation

NX CAE allows you to achieve these benefits through a fully integrated environment that combines all of the following:

- Advanced analysis modeling and superior geometry foundation
- Multi-discipline simulation and optimization
- Systems-level simulation
- HD-PLM for leveraging CAE results to make smarter decisions

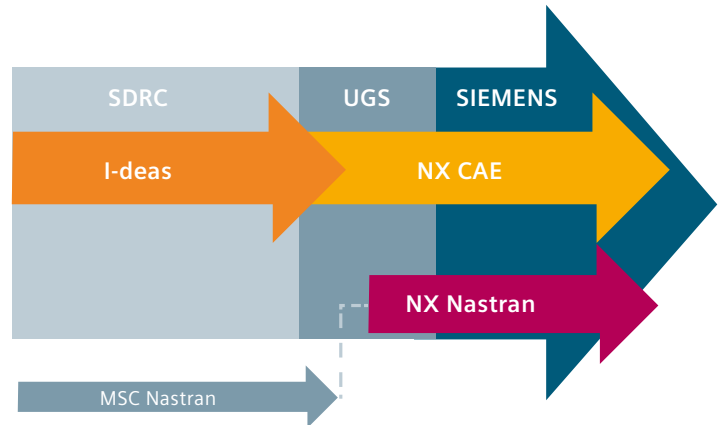

Advanced analysis modeling

“The NX associated modeling and meshing capability represents an extremely powerful tool. It allows us to optimize through models, thereby getting fast results at a low cost.”

Mark Dodd
Head of Group Research
KEF

NX CAE drastically reduces the time you spend preparing analysis models. NX delivers all the advanced meshing, boundary conditions and solver interfaces that experienced analysts expect for high-end analysis. But what makes NX CAE unique from all other preprocessors is how it integrates a superior geometry foundation that enables intuitive geometry editing and analysis model associativity to multi-CAD data. The tight integration of a powerful geometry engine with robust analysis modeling commands is the key reducing modeling time by up to 70 percent compared to traditional analysis modeling tools.

Comprehensive meshing tools

NX CAE includes extensive modeling functions for automatic and manual mesh generation of 1D, 2D and 3D elements and application of loads and boundary conditions.

1D element and beam meshing

Create 1D elements such as welds, bolts, rigids and more with ease in NX CAE. Beam section properties can easily be defined from a standard set of sections or directly from CAD geometry simplifying the task of generating the appropriate data for the beam definition.

2D shell meshing

Shell meshing is used for modeling thin-walled parts and can be used in conjunction with mid-surfaces. 2D meshing capabilities include mapped meshes, swept meshes, quad-only mesh options and transitioning from coarse to fine meshes.

3D meshing

NX CAE includes hexahedral meshing capabilities in addition to its “best-in-class” tetrahedral meshing. Analysts can also easily transition between hex and tet meshes within the model using pyramid elements.

Loads and boundary conditions

NX CAE provides extensive capabilities to define loading and boundary conditions to correctly simulate operating environments. Loads and constraints can be defined on and associated with geometry or can be defined directly on FE elements or nodes. Loads and constraints defined on geometry will also ensure element nodes are placed at load locations during automatic meshing.

Multi-CAE environments

NX CAE offers immersive user environments to support a variety of disciplines, such as CFD and thermal analysis, as well as other common solvers used by analysts including NX Nastran®, MSC Nastran, Abaqus, Ansys and LS-Dyna. The solver environments immerse the user in the language of the selected solver’s terminology which enables analysts to easily prepare solver-specific analysis models without the need to learn new terminology.

“With NX, CAE is an integral part of the design process. Meshing, solving, visualization: it’s all integrated and that’s what makes the whole approach viable.”

Paul Crooks
Head of Design
Wirth Research

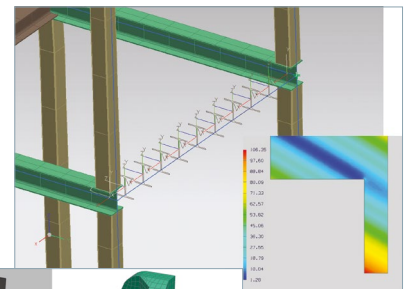
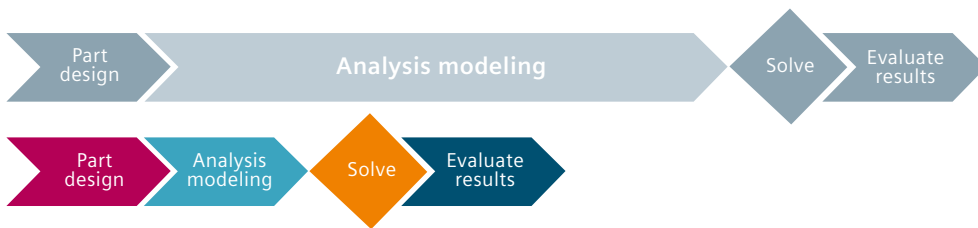
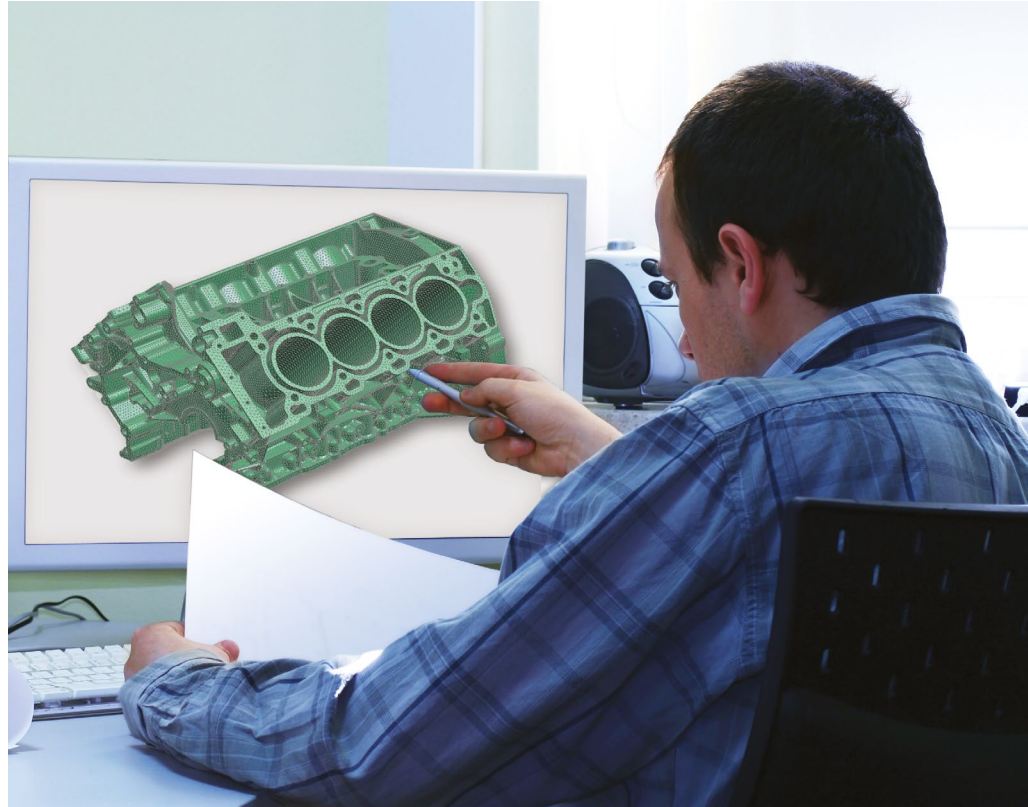

NX CAE reduces analysis modeling time by up to 70 percent

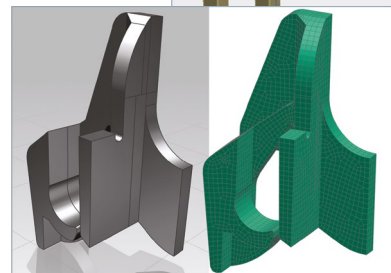

Superior geometry foundation

“The business case for using NX for CAE is immense and indisputable. Our productivity and our engineering efficiency have gone up significantly beyond normal measure and our development costs have plummeted. We have fewer steps but with each one we get a better return and we spend less doing it.”

Darren Davies
Engineering Manager
Wirth Research

NX CAE is built on the same leading geometry foundation that powers NX. Integrating strong geometry capabilities with CAE preprocessing results in enormous benefits for analysts.

Synchronous technology revolutionizes geometry editing

NX CAE includes the direct geometry editing capabilities powered by synchronous technology developed by Siemens. Analysts can quickly edit geometry in intuitive ways that cannot be done in traditional CAE preprocessors or feature-based CAD systems. Direct editing works on geometry from any source, and analysts can use it to rapidly modify geometry prior to meshing, create design alternatives for “what-if” kinds of simulation, or rapidly generate fluid domain volume geometry.

Geometry defeaturing and idealization

Features like small holes, small steps and slivers impact meshing speed and quality but can be irrelevant to engineering performance. With NX CAE, analysts can leverage direct editing to clean and defeature geometry in a fraction of the time of traditional CAE tools. Other geometry idealization capabilities include:

- Geometry healing and repair for gaps and other data inaccuracies
- Mid-surfacing for thin-walled solid bodies
- Split body and partitioning methods for dividing geometry into more manageable sections
- Merging/splitting/stitching of edges and faces for controlling mesh boundaries

Analysis model to geometry associativity

User-defined geometry edits, mesh and boundary conditions are all associated to the base design. When the design topology changes, NX rapidly updates the existing analysis geometry, mesh, loads and boundary conditions as required, avoiding the need for users to manually recreate the analysis model. This approach greatly reduces downstream modeling time which results in major time savings across a project’s many design-analysis iterations.

Multi-CAD support

NX CAE supports CAD geometry from a number of formats, and all NX CAE direct editing and idealization capabilities can be used on geometry from all of these formats. Analysis model associativity can even be maintained on imported geometry, and NX CAE will recognize what parts of the imported geometry have changed and update the analysis model accordingly. Geometry formats that NX CAE supports include: NX, CATIA V4 and V5, Pro/Engineer, Solid Edge® software, SolidWorks, Parasolid® software, IGES, STEP, and JT™ data format.

Geometry for motion

Motion analysis in NX CAE also takes advantage of the geometry foundation by automatically converting a CAD assembly into a motion model. Assembly constraints convert to the appropriate corresponding joints or connections, and the component geometry is used for the rigid body motion links.

“When analysis results demand design changes, we can apply these efficiently using synchronous technology. Re-meshing is effortless and results in very short design cycles.”

Jerry Baffa
Project Engineer
Research Department
Damen Shipyards Group

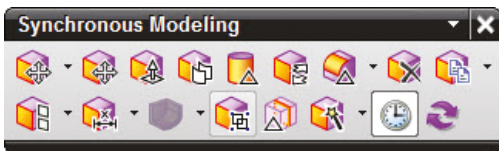
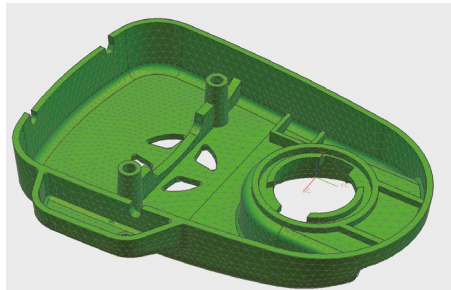
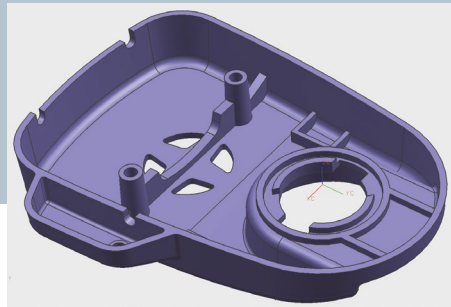
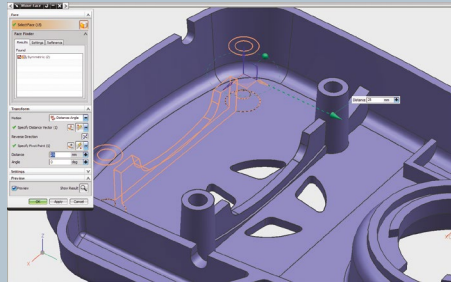
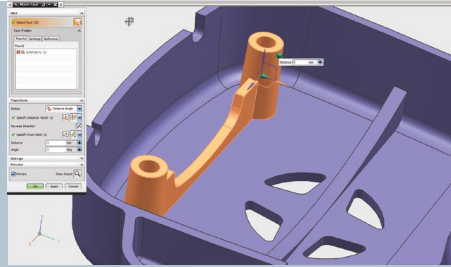
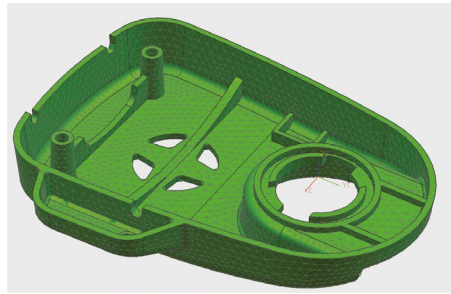

Multi-discipline simulation and optimization

“We worked with Siemens PLM Software on a simulation project that would have been impossible with our previous simulation tools. We completed the analysis in record time. It took just two days compared to five previously.”

Jack Webb
Senior analyst
Delphi

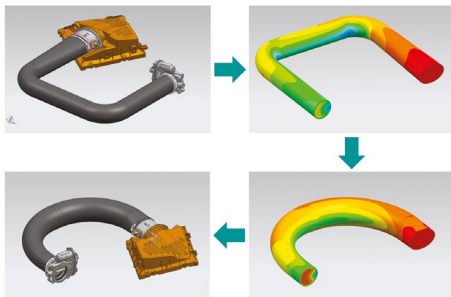

Geometry optimization of an intake duct

The need to use multiple analysis products adds costs and complexity because each analysis product has its own user interface and workflows. In addition, incompatible models and manual file transfers consume time and create errors which sometimes prevent the multi-discipline studies necessary to correctly understand product performance.

A single integrated environment

NX CAE reduces this complexity by delivering breadth and depth of analysis capabilities through a single advanced simulation environment. Whether you're conducting structural, thermal, flow, motion or a number of other types of analyses, you will always be within the same basic user interface, have access to the same base analysis and geometry modeling capabilities, and use the same file structure and management scheme. NX CAE also integrates with other well known solvers like Abaqus, Ansys, LS-Dyna and MSC Nastran, so you can use NX CAE as an all-purpose pre/postprocessing system for all your analysis needs.

Scalable analysis solver

NX CAE also leverages NX Nastran for a number of analysis types including linear and nonlinear structural solutions, dynamics and aero-elasticity. The same NX Nastran solver used for high-end analysis is also used within the designer-level application to ensure consistency of results.

Easier coupled-physics analyses

NX CAE simplifies the process of conducting coupled-physics analyses. The integrated modeling environment eliminates the need for error-prone external data transfers to link coupled-physics analyses together. Easier coupled-physics analysis workflows means you can spend more time simulating your product under conditions that more accurately represent the real world.

Simulation-driven design through optimization

The powerful geometry foundation within NX CAE can help companies achieve simulation-driven design. Analysts can use the direct geometry editing capabilities to create design variables which can be optimized against any kinds of simulation.

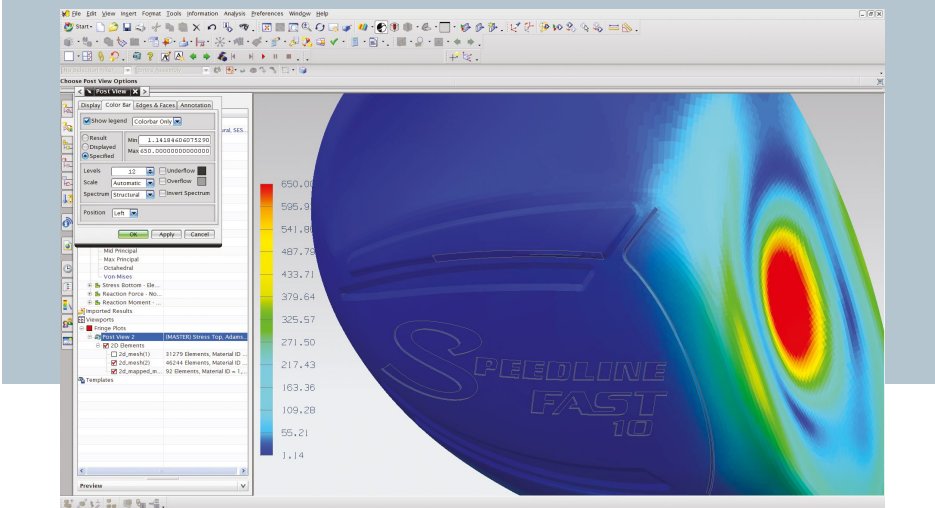
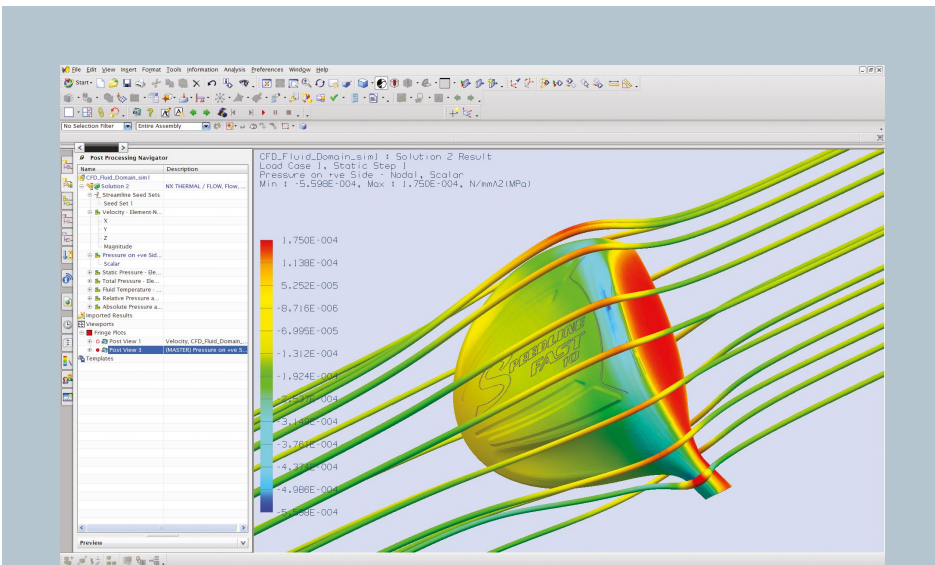

“We can take our 3D model, basically use that exact same 3D model, just click a button on the NX screen and we’re in stress and strain analysis. Click another button and we’re in a deflection analysis. Click another button and we’re running flow simulations. So being able to integrate all those different analysis tools right into our 3D modeling software has benefited us greatly as well.”

Jeff Albertsen
 Design Engineer
 Adams Golf

Depth and breadth of analysis capabilities

Linear and nonlinear structural analysis

- Static and dynamic stress
- Normal modes
- Buckling
- Stress stiffening and spin softening
- Modal analysis with differential stiffness
- Dynamic response analysis
- Nonlinear material models
- Large displacement, large strain
- Material hardening and creep
- Glue connections
- Node-to-node contact including friction
- 3D surface-to-surface contact
- Laminate composites analysis

Durability/fatigue analysis

- Strength and fatigue safety for cyclic loading (infinite life model)
- Advanced life and fatigue damage prediction (finite life model)
- Both uniaxial and biaxial stress cycles
- Utilize linear or nonlinear stress/strain results from FE models
- Utilize load time histories from physical test measurements

Thermal analysis

- Steady-state and transient
- Conduction, convection and radiation
- Advanced radiation and environmental heating

Flow analysis (CFD)

- Steady-state and transient
- Laminar and turbulent
- Incompressible and compressible
- Forced, natural and mixed convection
- Condensation
- Motion-induced flow
- General scalars and particle tracking
- Non-Newtonian fluids
- Multiple rotating frames-of-reference
- Two-phase flow

Coupled-physics

- Fluid-thermal
- Thermal-structural
- Fluid-structural
- Motion-structural

Materials

- Elastic-plastic material models
- Gasket material models
- Hyper-elastic material model extensions
- Fluid material models (nonflow)

Motion analysis

- Kinematics
- Multi-body dynamics
- Rigid and flexible bodies

Co-simulation

- Motion-control systems

Optimization analysis

- Geometry optimization
- FE model parameter optimization

External solver interfaces

- NX Nastran
- MSC Nastran
- Abaqus
- ANSYS
- LS-Dyna

Test/analysis correlation

- Validate mathematical models with physical prototype test results
- FE model updating – modal and FRF-based approaches

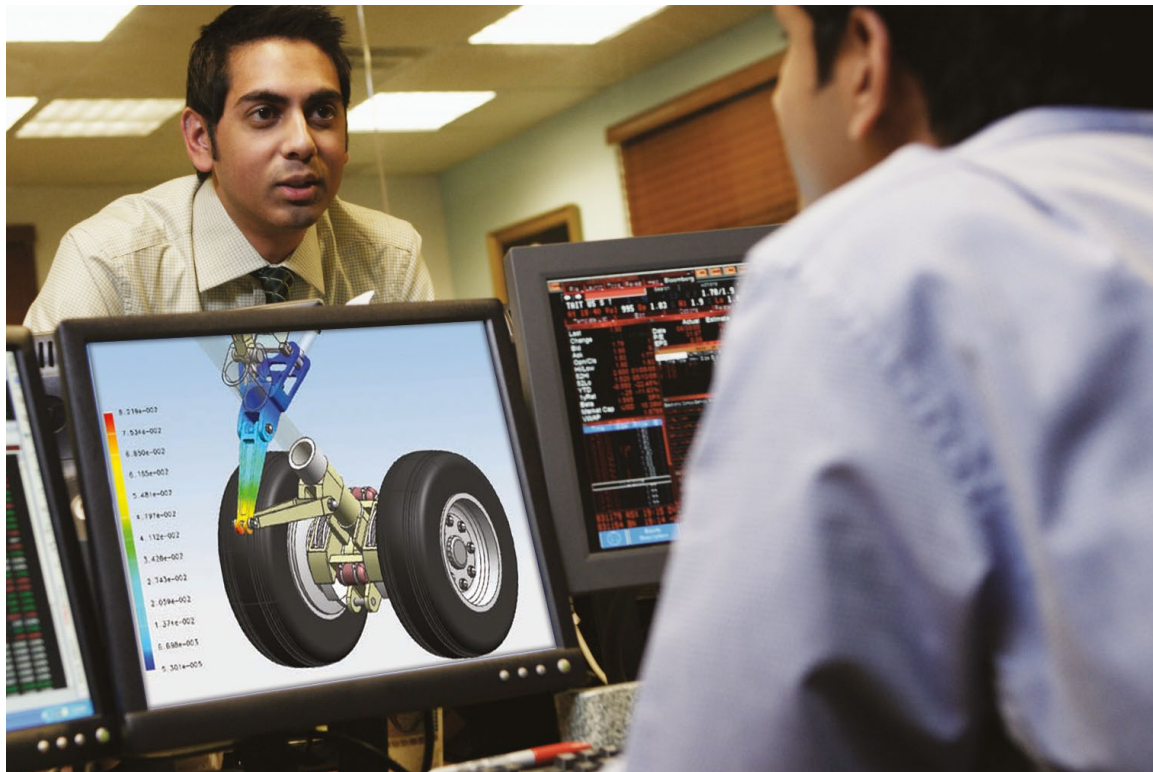
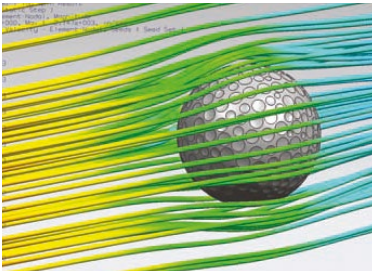
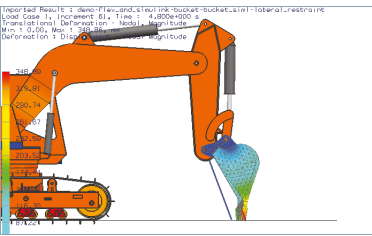
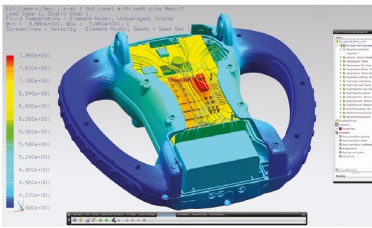

Systems-level simulation

“An additional advantage of NX and NX Nastran is scalability. We are able to provide tailor-made functionality to the users.”

Don Hoogendoorn
Project Engineer
Research Department
Damen Shipyards Group

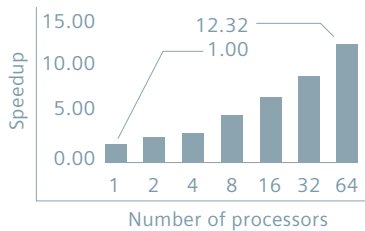

NX Nastran parallel processing performance:
Engine block model:
20 million degrees of freedom,
3.6 million node points,
frequency 0 – 10,000 Hz,
250 normal modes

As products become ever more complex, performing simulation at just the component level is not enough. NX CAE has the tools needed to efficiently build and manage complex analysis models and assemblies, perform advanced simulation and co-simulation with control systems, solve large models quickly using the latest in high-performance computing methods and correlate analysis results with physical tests.

Efficient FE assembly management

NX CAE is unique in the way it creates finite element assembly models. Unlike traditional CAE preprocessors that were developed for component analysis and require you to build large monolithic analysis models, NX CAE was developed to create large FE assembly models by instancing and connecting FE component models together, similar to a CAD assembly.

When an FE component is updated later in development, NX CAE updates all instances of that component within the FE assembly, eliminating the need to rebuild and connect a new FE assembly together.

Co-simulation with control systems

Today's products often have various controls using either electronics, hydraulics or software. Behavior of the control system impacts the mechanical system and vice versa, so it's critical for mechanical and controls engineers to understand the effects as they develop their systems.

NX CAE has the ability to co-simulate mechanical designs using motion analysis along with control systems designed and simulated in Matlab/Simulink. Co-simulation runs the motion analysis and controls simulation simultaneously so engineers can efficiently evaluate how the complete system will perform.

High-performance computing to solve large problems

Analysis models today can routinely be on the order of 10 – 20 million DOFs in size, and this size could double within the next five years. Siemens develops NX CAE and NX Nastran to keep ahead of the pace in terms of solver performance so that you can efficiently solve increasingly large analysis problems. Using distributed memory parallel (DMP) and shared memory parallel (SMP) processes, NX CAE can speed structural and flow simulations by 10 to 20 times.

Correlating analysis results with physical tests

Before a test can be replaced, you need to demonstrate that the analysis model can match measured data. NX CAE can quantitatively and qualitatively compare simulation and physical modal test results, as well as compare two results from different simulations. A high degree of correlation between the analysis results and test data gives you confidence simulation will accurately predict performance and allow you to reduce the number of physical tests.

HD-PLM for smarter decisions

“NX is powerful software and a leader among engineering automation systems.”

B. Galchenko
Vice Engineering
Director for Development
JSC Aviaagregat

“We spend about 75 percent of the simulation time in model preparation. Using the automated process enabled by NX, we cut about 60 percent of the model preparation time.”

Patrice Klein
Simulation Manager
CAE Analysis Group
LOHR

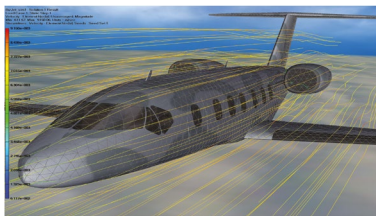

HD-PLM is about making smarter decisions to develop better products, and simulation is crucial to making smarter product development decisions. NX CAE helps raise the visibility of critical simulation results so decision makers have access to the latest and most accurate product performance information.

Data management designed for the CAE analyst

NX CAE seamlessly integrates with the entire Teamcenter® data management portfolio, including the simulation process management module. Simulation data management capabilities work “out of the box”, and companies can implement a complete environment for managing CAE data, process and workflow as part of a wider product development environment. This reduces waste by promoting re-use of existing designs and engineering knowledge. It synchronizes data and makes it readily accessible through data mining, visualization and reporting.

Linking simulation results to product requirements

NX CAE lets you link simulation results directly to specific product requirements and can alert project managers when requirements are not being met. Project managers and other product decision makers can then view the 3D simulation results in an intuitive way using JT, a light-weight visualization tool.

Automating simulation processes

CAE engineers can increase productivity by automating redundant processes with NX Open, the common foundation for automation and programming in NX. Using NX Open, expert CAE users can capture, author and publish simulation processes to guide less experienced engineers or designers accelerate the development process, while ensuring modeling and results accuracy.

An open platform

Siemens understands you often need to use other software tools, either developed internally or from other vendors, to get the answers you need to support critical development decisions. That’s why NX CAE is open and flexible enough to allow you to incorporate those tools into your simulation processes. NX CAE supports a number of commercial CAE solvers through available environments, or you can develop your own interfaces using NX Open.

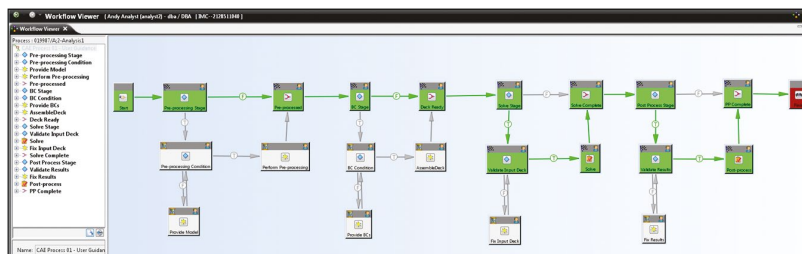

NX CAE product list

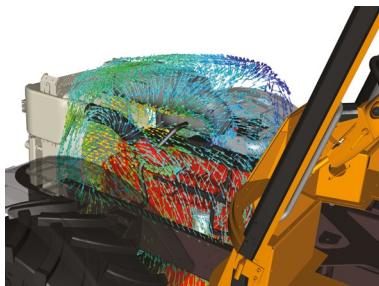
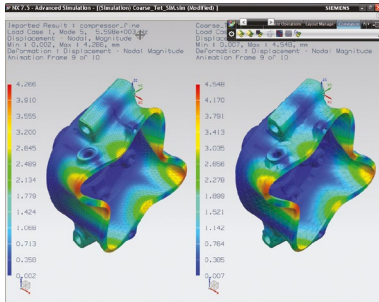

NX Advanced Simulation – an open, multi-CAD and CAE solver-neutral environment that enables rapid simulation as an integral part of the design process. Extensive geometry idealization and abstraction capabilities support rapid simulation in a geometrically complex, multi-physics environment. Powered by an integrated NX Nastran desktop solver, users have direct access to comprehensive model review, structural optimization and results visualization capabilities to enable design decisions to be based on insight into real-world product performance.

NX Advanced FEM – the power and functionality of NX Advanced Simulation for customers who wish to use an alternative solver (does not include NX Nastran).

Solver environments for Ansys, Abaqus, LS-Dyna and Nastran – add-ons to NX Advanced FEM that tailor the FE modeling user interface and analysis process in language specific to the FE solver.

NX Response Simulation – an interactive, visual environment for linear evaluation of the structural dynamic response of a system when subjected to complex loading conditions such as random vibration, transient, harmonic and shock spectra.

NX Flow and NX Advanced Flow Simulation – a complete suite of CFD simulation capabilities available as add-ons in the NX Advanced Simulation environment. You can seamlessly conduct multi-physics simulation when combined with NX Thermal or NX Advanced Thermal.

NX Thermal and NX Advanced Thermal Simulation – a complete suite of thermal simulation capabilities available as add-ons within the NX Advanced Simulation environment. You can seamlessly conduct multi-physics simulation when combined with NX Flow, NX Advanced Flow or NX Nastran.

NX Electronic Systems Cooling Simulation – an integrated solution that enables evaluation of the cooling effects of airflow around enclosed, densely packed heat-generating electronics systems used in many industries.

NX Space Systems Thermal Simulation – an integrated solution that enables evaluation of complex heat transfer characteristics of space systems during both orbital and interplanetary missions.

NX Laminate Composites – an extension to the NX Advanced FEM or Advanced Simulation packages, this integrated capability is uniquely tailored to the productive design and evaluation of laminate composite structures.

NX Advanced Durability and NX Durability Wizard – advanced simulation products for calculating the fatigue life of mechanical components subjected to cycles of loading. Both products are extensions to the NX Advanced FEM or Advanced Simulation packages.

NX FE Model Correlation and NX FE Model Updating - an add-on to Advanced FEM or Advanced Simulation that quantitatively and qualitatively compares simulation results and physical modal test results, as well as compares two different simulations. FE Model Updating enables automatic adjustment and optimization of the analysis model to improve its correlation with physical modal test results.

NX Motion Simulation, NX Motion Flexible Body and NX Motion Control – a design-integrated environment for evaluating the kinematic and dynamic performance of new product designs. Mechanisms can include flexible bodies for coupled motion-structural analysis as well as perform co-simulation with control systems developed in Matlab/ Simulink.

NX Design Simulation – a design-integrated and easy-to-use NX application that enables design engineers to quickly evaluate the structural performance characteristics of 3D product design concepts earlier in the development process.

NX Nastran – available standalone as an enterprise solution or seamlessly integrated at the core of many NX CAE products. NX Nastran delivers comprehensive performance simulation capabilities for a broad range of engineering disciplines and industries. Siemens is dedicated to making NX Nastran the most complete and powerful solution available for functional digital prototyping and simulation.

Teamcenter simulation process management – a CAE-specific Teamcenter module that enables the capture, re-use and sharing of simulation data, CAE product structure and simulation processes across the enterprise.

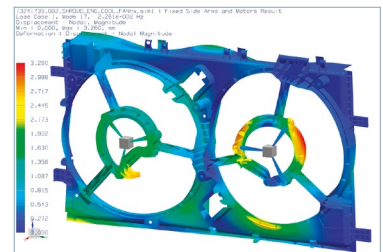
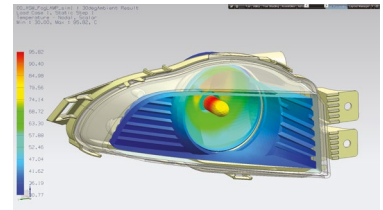
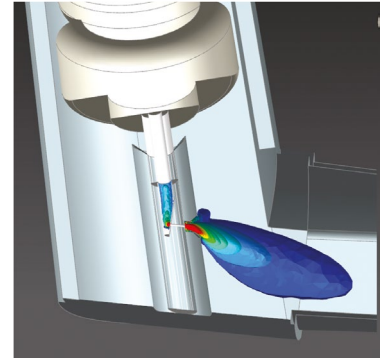

About Siemens PLM Software

Siemens PLM Software, a business unit of the Siemens Digital Factory Division, is a leading global provider of product lifecycle management (PLM) and manufacturing operations management (MOM) software, systems and services with over nine million licensed seats and more than 77,000 customers worldwide. Headquartered in Plano, Texas, Siemens PLM Software works collaboratively with its customers to provide industry software solutions that help companies everywhere achieve a sustainable competitive advantage by making real the innovations that matter. For more information on Siemens PLM Software products and services, visit www.siemens.com/plm.

Headquarters
Granite Park One
5800 Granite Parkway
Suite 600
Plano, TX 75024
USA
+1 972 987 3000

Europe
Stephenson House
Sir William Siemens Square
Frimley, Camberley
Surrey, GU16 8QD
+44 (0) 1276 413200

Americas
Granite Park One
5800 Granite Parkway
Suite 600
Plano, TX 75024
USA
+1 314 264 8499

Asia-Pacific
Suites 4301-4302, 43/F
AIA Kowloon Tower,
Landmark East
100 How Ming Street
Kwun Tong, Kowloon
Hong Kong
+852 2230 3308

© 2015 Siemens Product Lifecycle Management Software Inc. Siemens and the Siemens logo are registered trademarks of Siemens AG. D-Cubed, Femap, Fibersim, Geolus, GO PLM, I-deas, JT, NX, Parasolid, Solid Edge, Syncrofit, Teamcenter and Tecnomatix are trademarks or registered trademarks of Siemens Product Lifecycle Management Software Inc. or its subsidiaries in the United States and in other countries. All other logos, trademarks, registered trademarks or service marks belong to their respective holders.

4153-X24 7/15 B



844-GEO-SUPT
support@geoplms.com
geoplms.com