

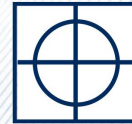

SIEMENS

Ingenuity for life



**GEOMETRIC
SOLUTIONS**

NX Layout

Accelerating the product design process with 2D conceptual design

Benefits

- Leverage a familiar drawing environment
- Eliminate the need to maintain a 2D legacy system
- Explore concepts in a 2D environment
- Improve designer efficiency and productivity
- Easy transition from 2D to 3D
- Reduce the need for translation

Features

- Fully integrated and built on existing, proven technology
- Intelligent, design-centric, re-usable 2D components
- Ability to create 3D objects from layout

Summary

Concept design is easier than ever with NX™ software. NX Layout is fully integrated with NX and lets you quickly explore design concepts in 2D to accelerate the product design process. The integration of NX Layout in drafting allows you to leverage a familiar 2D environment and take advantage of essential 2D functions. A 2D component is analogous to a 3D part in the context of a 2D environment. They can be created and organized in a multilevel hierarchical structure, and managed for re-use in other layouts. As a result, 2D components provide a unique, more efficient and productive method for designing in 2D. Furthermore, with NX

Layout you can automatically create 3D assemblies and parts from the 2D component structure of your layout. Using NX Layout eliminates the time and effort associated with translating or recreating designs in 3D.

Concept design

The nature of concept design

Concept design is the first phase of design. It creates the foundation for product design, which includes everything from modeling, styling, simulation, analysis, validation, inspection, documentation and whatever else is needed for a particular design. Fundamentally, the goals of conceptual design and product design differ. When you are involved in the concept design phase, you are less concerned about the specific details of the finished product; however, when it comes to product design, the details are essential for completing the design and documentation so you can ultimately manufacture a product.

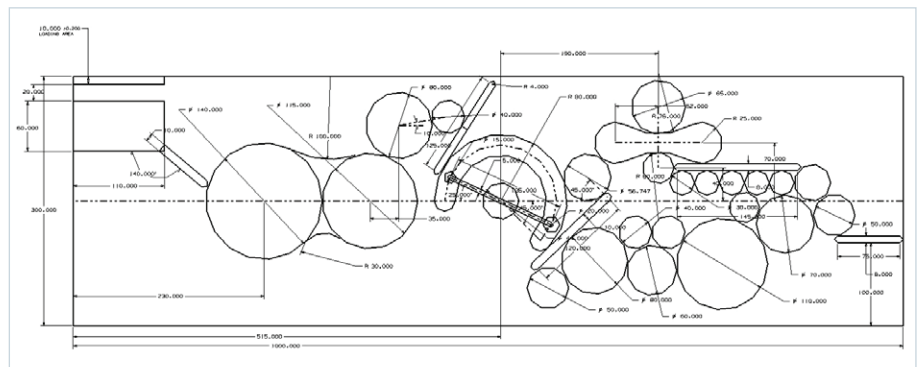

The concept phase is the most important part of design.

NX Layout

Therefore, the concept phase of design is the most important stage. It's when the broadest outline of the design takes shape, and large changes can be made quickly and easily. If you get the concept right, the rest of the design is much more likely to be successful. Having the proper tool for concept design enables you to succeed. With the right tool, you can exercise creativity, investigate multiple solutions to design problems and develop promising ideas to see how well they will work. It's an opportunity to think outside-the-box. The right concept design tool will help you visualize the design and how it will interact with its environment in a simple, intuitive way. It will allow you to incorporate requirements and validate them as you explore design alternatives. A great concept is a road map to follow throughout the design and manufacturing process. A great tool is one that helps you find that concept.

Concept design challenges

Although a significant amount of design work is now done in 3D, many companies continue to use dedicated 2D computer-aided design (CAD) tools for early conceptual design. Companies that use 2D CAD for conceptual design generally believe that design problems that have key characteristics represented in 2D are better addressed in 2D, and that 2D designs are easy to study, share, print and discuss. So while the benefits of 3D are significant and no less important to a company's overall design strategy, sometimes it is just easier to design or produce a layout in 2D.

Today's 2D CAD solutions provide significant capabilities; however, they lack tools that enhance the design process. They typically provide a set of generic tools that do not deliver the functionality necessary to support accelerating the product design phase. This leads to

reduced productivity and less motivation to commit to conceptual design. Ultimately, it means reduced long-term competitiveness. Providing dedicated tools that support design enhances designer experience and improves productivity.

For all the benefits of 2D concept design, however, there is still usually a need to complete the detailed design in 3D. Using separate systems for 2D concept design and 3D detailed product design is one way to accomplish this, but it tends to be inefficient and prone to errors. Because it adds cost and time to the design process, some companies skip 2D concept design altogether, which means they miss out on the benefits of a quality concept design. This can lead to problems during the product design phase, causing further delays and increased costs. The optimal solution, therefore, is to perform 2D concept design and 3D product design in a single system.

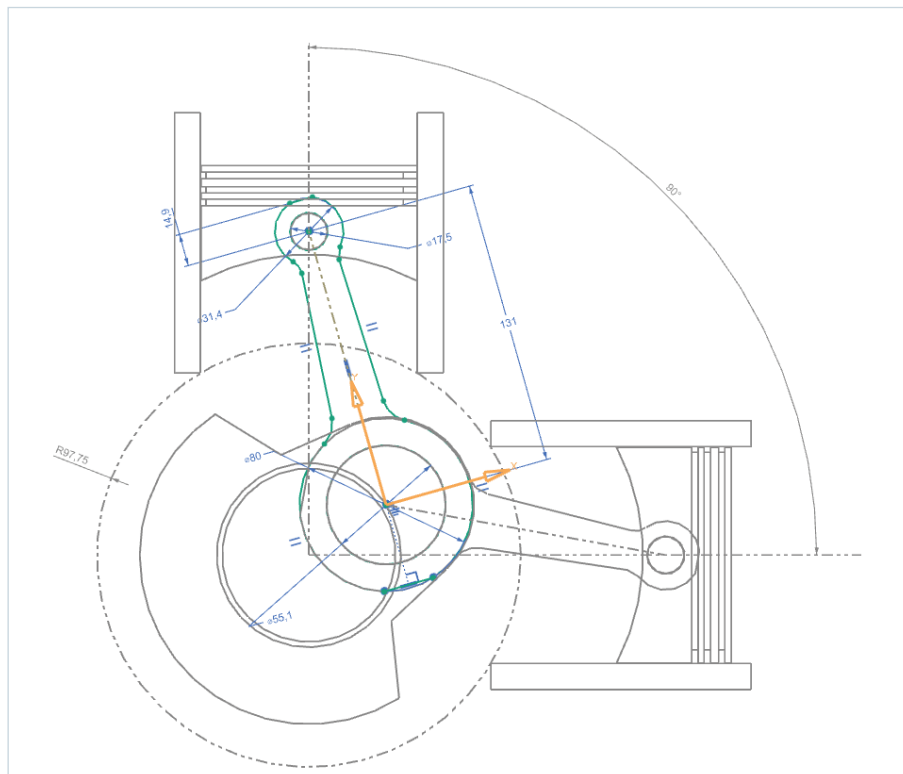

Designing in 2D is an efficient way to solve many problems.

NX Layout

Overview

NX Layout is a fully integrated 2D concept design solution for NX. Built on proven NX technology, it uses intelligent, re-usable objects called 2D components to enhance 2D concept design. NX Layout provides a number of dedicated tools to support 2D design and delivers powerful 2D-to-3D capabilities to accelerate the product design phase.

Fully integrated

The NX Layout toolset is fully integrated with the NX Drafting application, however, the focus of NX Layout is on 2D design versus traditional documentation requirements. This integration allows you to leverage a familiar 2D environment and take advantage of essential 2D functions, such as sketching, dimensions and annotation. It also means you can take advantage of synchronous technology for 2D design, a breakthrough innovation for working with 2D data.

Since very few designs start with a blank sheet, NX Layout supports the import of neutral formats such as DXF, DWG and IGES as well as direct importers for AutoCAD Blocks and I-DEAS drawings and symbols, allowing you to take advantage of legacy data. NX Layout lets you use the same, familiar drawing environment as NX Drafting, so the learning curve is minimal, and you have a full, comprehensive set of 2D design tools and the same customizable user interface as you use for any other area of NX. Since all NX documentation capabilities are available in NX Layout, you can document your concept design at any time, as well as print or plot it.

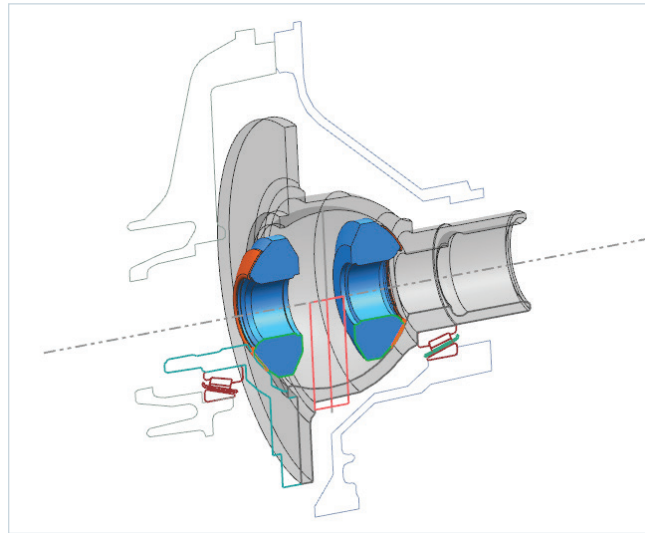

Easily create 3D parts from 2D curves.

Providing a key element for 2D conceptual design

The 2D component is a key element of NX Layout; an intelligent, parametric, re-usable object dedicated to 2D design. A 2D component is analogous to a 3D part in the context of a 2D environment and can consist of any combination of sketch geometry, dimensions, annotation or embedded 2D components. Creating a new 2D component is easy. You can also create empty 2D component instances, providing a quick way to generate a virtual structure for a

concept design. The 2D components can be organized in a hierarchical structure similar to the way an assembly is generated in the context of a 3D environment. Like assembly components, they can be associative to each other or other objects, and they can also be copied and edited in context. You can drag-and-drop 2D components from the Reuse Library to ensure quality and save design time. Since 2D

components are re-usable, they enable you to quickly and easily create layouts and concept designs. Overall, they drive a more efficient and productive method of 2D concept design.

Create an assembly with NX Layout

One of the main advantages of NX Layout over traditional 2D concept design methods is the ability to take your 2D design directly into 3D. You can automatically create an assembly and parts from the 2D component hierarchy of your layout. Once they are in 3D, you can create 3D geometry from the 2D geometry. With NX Layout, there is no need for multiple CAD systems, translations or recreating geometry, so you don't experience the wasted time or errors associated with these methods. The 2D components come into 3D as constrained, parametric sketches that can easily be modified. So when you finish your design in 2D, you are already well on your way to a complete 3D model. Not only does this accelerate the product design phase, but it makes users more likely to take advantage of 2D concept design since they know the transition from 2D to 3D will be less time consuming and error prone than with older methods.

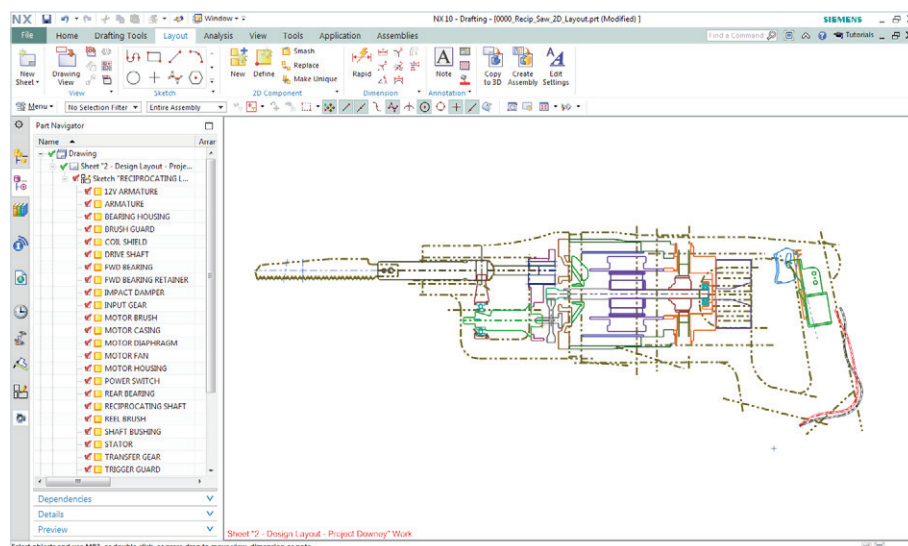

NX Layout is fully integrated and uses the same data set and interface as the rest of NX.

Conclusion

NX Layout is an easy-to-use 2D concept design solution for NX, which is integrated with a common user interface in proven technology. It enhances 2D conceptual design with the use of intelligent, design-centric, re-usable objects called 2D components. Automatically creating an assembly based on a layout accelerates the product design phase by allowing you to explore concepts in 2D, and iterate and transfer it to 3D. Since it eliminates the need to maintain multiple systems to solve 2D design requirements, NX Layout also reduces the cost of training, maintenance and implementation.

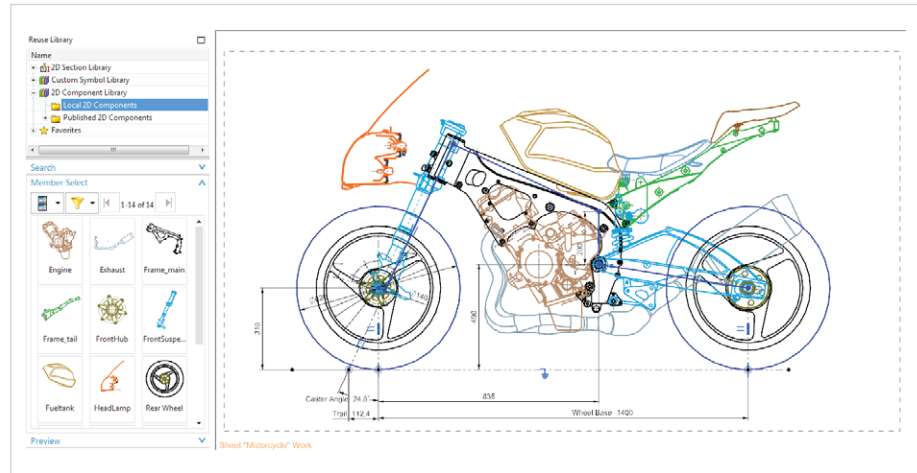

The 2D components are a key element in NX Layout.

Siemens PLM Software
www.siemens.com/plm

Americas +1 314 264 8499
 Europe +44 (0) 1276 413200
 Asia-Pacific +852 2230 3308



844-GEO-SUPT
support@geoplms.com
geoplms.com

© 2017 Siemens Product Lifecycle Management Software Inc. Siemens and the Siemens logo are registered trademarks of Siemens AG. D-Cubed, Femap, Fibersim, Geolus, GO PLM, I-deas, JT, NX, Parasolid, Solid Edge, Syncrofit, Teamcenter and Tecnomatix are trademarks or registered trademarks of Siemens Product Lifecycle Management Software Inc. or its subsidiaries in the United States and in other countries. All other logos, trademarks, registered trademarks or service marks belong to their respective holders.

48659-A7 1/17 H