



**SIEMENS**

*Ingenuity for life*



**GEOMETRIC  
SOLUTIONS**

# NX Turbomachinery Milling

## Machine blisks and impellers with expert results in half the time

### Benefits

- Reduce model preparation time and effort
- Quickly and easily program highly complex 5-axis rotational parts
- Machine parts faster
- Achieve a high quality surface finish
- Produce parts within specification
- Increase tool life
- Automate design change update

### Summary

NX™ software's Turbomachinery Milling simplifies the NC programming process for machining complex 5-axis multi-bladed rotational parts, such as blisks and impellers for aero-engines, turbomachinery and power generation equipment. By putting NC programmers in the context of 5-axis rotational part machining, programmers are able to use advanced operations specifically designed to produce smart tool paths for blisks and impellers. This results in faster machining times, better surface finish and longer tool life.

### Process-specific NC programming functions for blade/blisk machining

You can leverage NX Turbomachinery Milling to reduce programming effort by applying 5-axis NC programming functions configured specifically for machining multi-bladed, multi-axis rotational parts. Blades can be curved with undercuts. In addition, multiple splitters are supported.

NX Turbomachinery Milling enables you to work effectively with any CAD data regardless of its originating system. Blades can be made of one or many surfaces. Gaps and overlaps between surfaces are healed automatically. You can produce smooth flowing tool paths on adjacent surfaces with inconsistent UV parameter lines.

This application enables you to save time by defining machining operations for one section of the blisk/impeller and then automatically completing the remainder of the part.

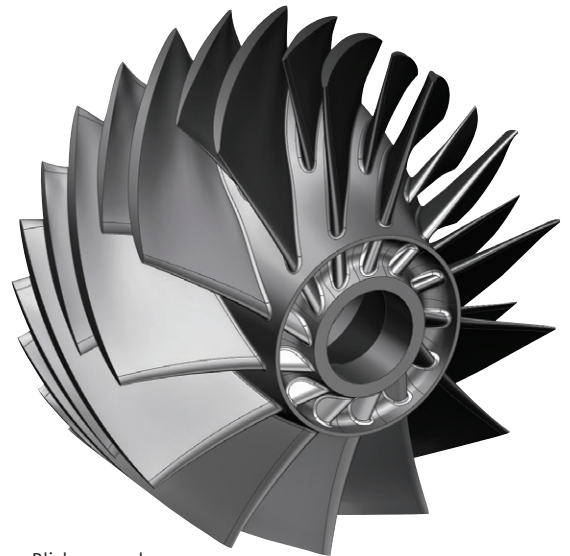

Blisk example.

# NX Turbomachinery Milling

## Features

- Process-specific functions for blade/blisk machining
- Ability to machine single or multiple splitters
- Simultaneous 5-axis roughing
- Hub finishing
- Blade/splitter finishing
- Tool axis and tool path smoothing
- Holder collision checking and avoidance
- Ability to automatically heal input geometry
- Feed rate optimization
- Associative tool paths and operations

## Specialized NC programming operations for blisks and impellers

**Simultaneous 5-axis roughing**, which enables you to perform highly flexible 5-axis roughing (without the need for auxiliary control surfaces) by specifying parameters such as tool take-off, cut level offsets, depth of cut limits, drive pattern, step-over, the number of passes between blades, tool axis, smoothing options and path extension treatments for leading and trailing edges. Flat, bull-nosed or ball-end mills are available.

**Rest milling**, which automates removal of remaining material from previous operations, as well as optimizes tool engagement with the part in an effort to minimize wasted air cutting time.

**Hub finishing**, which enables you to apply specially optimized tool paths designed for finishing impeller and blisk hubs, as well as precisely control the side step-over, cut pattern and tool angle.

**Machining of splitters**, which facilitates NC programming automation for parts with single or multiple splitter combinations.

**Blade/splitter finishing**, which you can use to finish blades and splitters by specifying which sides of the blade to cut (section/pressure/both), as well as path pattern and tool axis stabilization parameters for leading and trailing edges. True spiral patterns are available for constant cutting. Go-to points are synchronized across and along the blade surface to maintain the best possible surface finish. Swarf cuts may be used when appropriate.

**Thin blade finishing**, which provides incremental roughing and finishing in order to reduce vibration of thin blades by keeping structural support (uncut material) in place below the finish cuts.

**Blend finishing**, which you can use to finish the blends around blades and splitters.

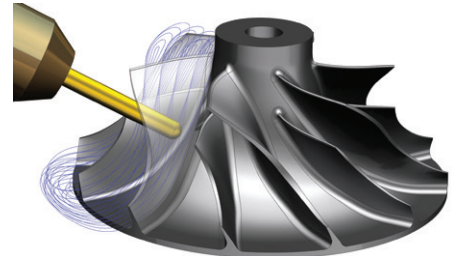

Roughing.



Rest milling.



Hub finishing.

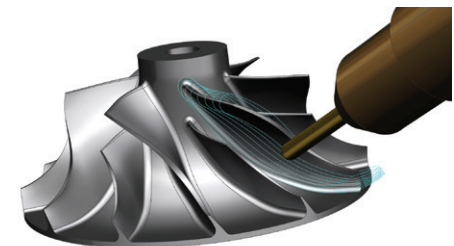

Blade finishing.

### Valued capabilities specifically for blisks and impellers

**Slotting pass**, which automatically identifies slotting passes and either applies a slower feed rate, or provides multiple slotting depths for better tool life.

**Tool path and tool axis smoothing**, which automatically applies smoothing algorithms to the tool axis/path and noncutting moves (to facilitate smooth flowing and completely gouge/collision-free results); this capability also automatically produces a high quality surface finish.

**Tool axis stabilization near leading and trailing edges**, which provides options for controlling the tool axis angle near leading and trailing edges.

**Interactive manual adjustment of tool axis**, which maintains smooth interpolations across the entire pass, previews the modified interpolations, and continues to ensure gouge avoidance.

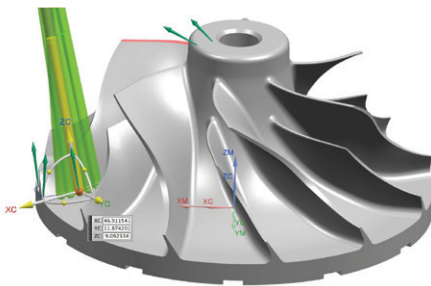

Manual adjustment of tool axis.

**Tool path extension at leading and trailing edges**, which provides options to control both tangential and radial extension types for leading and trailing edges.

**Step-over and depth of cut**, which provides options for controlling scallop, number of passes and offset distance.

**Gouge and collision free tool path**, which detects and prevents gouges with automatic tool path truncation for gaps between blades/splitters too small for the selected tool diameter. You also leverage this feature to detect and avoid collisions between the tool and blade-stabilizing clamping fixtures.

**Preview**, which shows temporary graphical feedback when machining parameters are selected. Instant graphical feedback is given when you select parameters such as depth of cut and step-over. You can also specify machining parameters, such as the tool path starting point, directly on the graphics window.

### Supporting NX CAM capabilities

**Feed rate optimization**, which automatically analyzes the tool path for tool loading and adjusts the feed rate to establish an optimum uniform rate of material removal – thereby facilitating longer tool life.

**Associativity**, which associatively links tool path updates to CAD model design changes.

**Online post processor library**, which enables you to access and download postprocessors for commonly used machine tool and controller configurations.

**NX Post Builder**, which you can use to configure your own postprocessor without the need for advanced programming skills.

**G-code driven machine tool simulation**, which verifies machining inside NX CAM using a machine tool model with kinematics and g-code output from the NX postprocessor.

### Product prerequisites

NX Turbomachinery Milling requires the NX CAM foundation plus 3- and 5-axis milling as prerequisites.

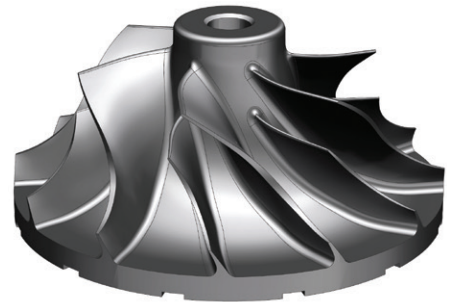

Impeller example.

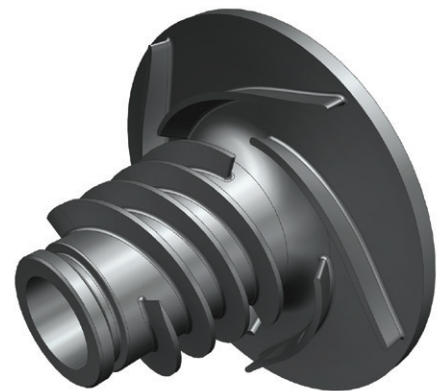

Multi-stage inducer example.

Siemens PLM Software  
[www.siemens.com/plm](http://www.siemens.com/plm)

Americas +1 314 264 8499  
Europe +44 (0) 1276 413200  
Asia-Pacific +852 2230 3308

© 2017 Siemens Product Lifecycle Management Software Inc. Siemens and the Siemens logo are registered trademarks of Siemens AG. D-Cubed, Femap, Fibersim, Geolus, GO PLM, I-deas, JT, NX, Parasolid, Solid Edge, Syncrofit, Teamcenter and Tecnomatix are trademarks or registered trademarks of Siemens Product Lifecycle Management Software Inc. or its subsidiaries in the United States and in other countries. All other trademarks, registered trademarks or service marks belong to their respective holders.

20646-A10 8/17 H

