



SIEMENS

Ingenuity for life



**GEOMETRIC
SOLUTIONS**

Simcenter 3D Advanced Thermal

temperature results to NX™ Nastran® software.

Simcenter 3D Advanced Thermal continues Siemens' long heritage in thermal simulation and leverages the same technology that underpinned the I-deas™ TMG solution. Simcenter 3D Advanced Thermal adds a rich feature set to the powerful simulation technology of Simcenter 3D Thermal. Intended for tackling complex thermal physics and challenging thermal management problems, Simcenter 3D Advanced Thermal offers the same best-in-class level of integration within the Simcenter 3D preprocessing, postprocessing and simulation tools.

Applications of Simcenter 3D Advanced Thermal include simulation and analysis of a range of heat transfer problems in aerospace, automotive, electronics, power, process and other industries. Simcenter 3D Advanced Thermal offers the following additional features on top of the Simcenter 3D Thermal license.

Extend thermal analysis solutions

Benefits

- Extend thermal solution capabilities in Simcenter 3D Thermal and Simcenter 3D Electronic Systems Cooling
- Solve complex heat transfer phenomena with a comprehensive set of modeling tools
- Reduce costly physical prototypes and product design risk through high-fidelity thermal simulation
- Gain further insight through coupled thermo-fluid multiphysics analysis using Simcenter 3D Advanced Thermal with Simcenter 3D Flow or Simcenter 3D Advanced Flow
- Leverage all the capabilities of the Simcenter 3D integrated environment to make quick design changes and provide rapid feedback on thermal performance

Summary

Simcenter™ 3D Advanced Thermal software extends the modeling and simulation capabilities of Simcenter 3D Thermal or Simcenter 3D Electronic Systems Cooling. Simcenter 3D Advanced Thermal provides a wide range of methods for advanced radiation analysis, radiative and electrical heating models, advanced materials models such as phase change, charring and ablation, as well as one-dimensional hydraulic network modeling. Thermo-fluid coupling is enabled with Simcenter 3D Flow and Simcenter 3D Advanced Flow, and thermoelastic effects can be simulated by mapping

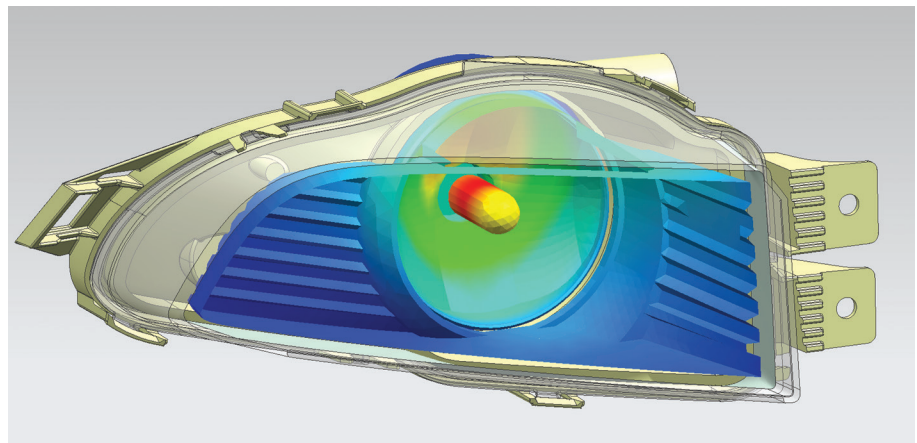

Simcenter 3D Advanced Thermal

Advanced optical properties

- Specular reflectivity, diffuse and non-diffuse transmissivity, index of refraction, solid absorption
- Direction-dependent optical properties, bidirectional reflectance distribution function (BRDF)
- Wavelength-dependent properties for nongray analysis

Advanced material models

- Ablation and charring models
- Electrical resistivity and Joule heating

Advanced radiation methods

- Deterministic and Monte Carlo ray tracing
- Nongray multiband radiative heat transfer

Radiative heating

- Solar heating with atmospheric attenuation and albedo flux models
- Radiative source definition, collimated or diffuse, spectrum-dependent, time and spatially varying flux

1D hydraulic network modeling

- 1D flow modeling using duct networks
- Ability to simulate convection to and from 1D duct networks
- Film cooling model
- Linear or exponential advection discretization

Advanced thermal couplings

- Perfect contact
- One-way conductances
- Free and forced correlation-based convection couplings
- Convective gap couplings
- User-defined couplings
- Cyclic symmetry couplings

Articulation and motion modeling

- Any combination of translational motion and rotational joints
- Time-dependent radiation and thermal couplings
- Postprocessing of articulated mesh
- Solid Motion Effects toolset that includes articulation and spinning effects

Thermal control devices

- Peltier cooler models
- Active heater controllers, PID controllers

Advanced simulation options for thermal analysis of turbomachinery and rotating systems

- Tightly-coupled thermo-mechanical analysis with NX Nastran for axisymmetric, 2D and 3D representations.
- Internal air system modeling with specialized Boundary Conditions: Streams, Voids and Convecting Zones.
- Comprehensive symbolic expression system for correlation-based modeling of convection and viscous heating, with a dedicated user API.

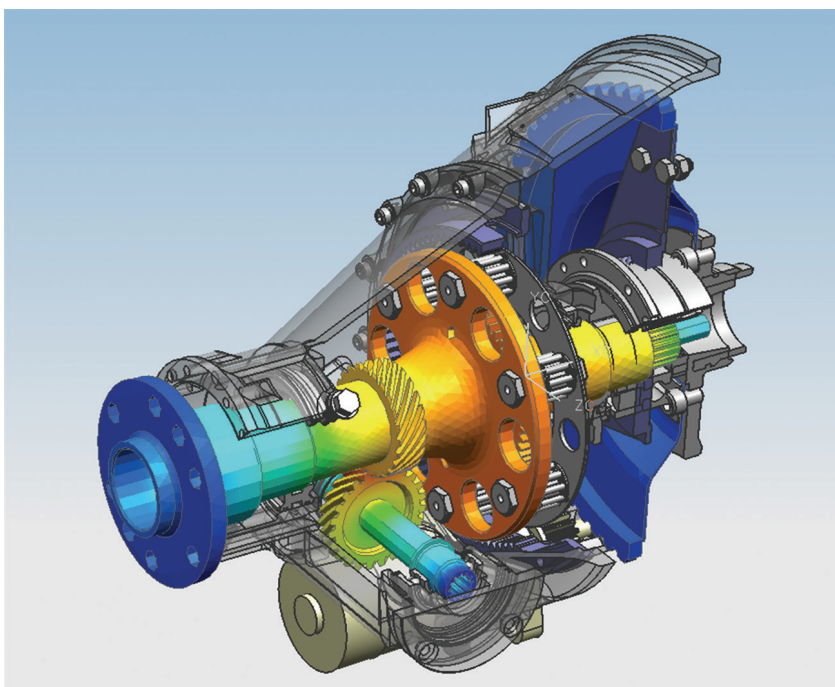
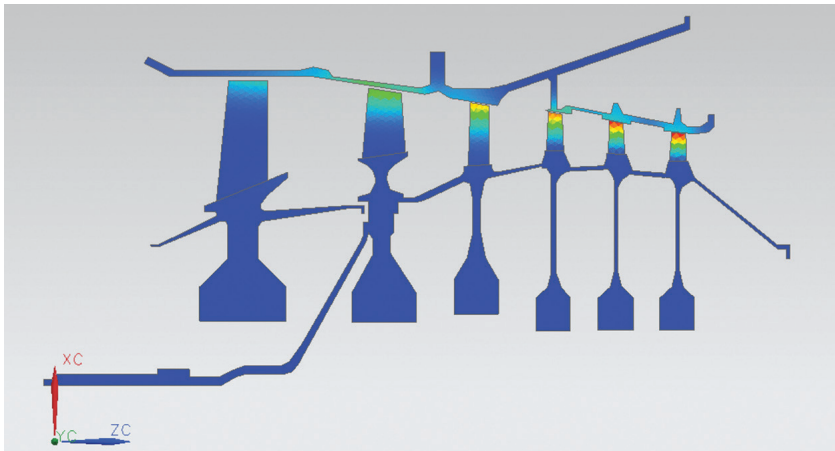

Multiphysics environment support

Simcenter 3D Advanced Thermal enables the multiphysics environment to solve thermomechanical problems in loosely (one-way) or tightly coupled (two-way) modes.

This environment delivers a consistent look and feel for performing multiphysics simulations so you can easily build coupled solutions on the same mesh using common element types, properties and boundary conditions, as well as solver controls and options.

Coupled thermal-structural analysis enables you to leverage the NX Nastran SOL 401 multi-step nonlinear solver and a thermal solution from the Simcenter 3D Thermal solver.

Open architecture

- Full access to thermal system equations
- Incorporation of external models
- Enhanced solution control
- User subroutines for integration of custom code in the solution sequence
- Coupling with external CFD codes

Parallelized thermal solver

- Parallel view factor calculations and solution of the thermal model based on the number of available cores for solution efficiency
- The Simcenter 3D Advanced Thermal product includes access to up to eight cores on one machine for the supported solver modules
- The available Simcenter 3D Thermal/Flow DMP add-on removes any software limitations on the number of cores and enables network and cluster support
- Distributed memory (MPI) based parallelization for highly scalable solution of thermal models – available with the Simcenter 3D Thermal/Flow DMP add-on

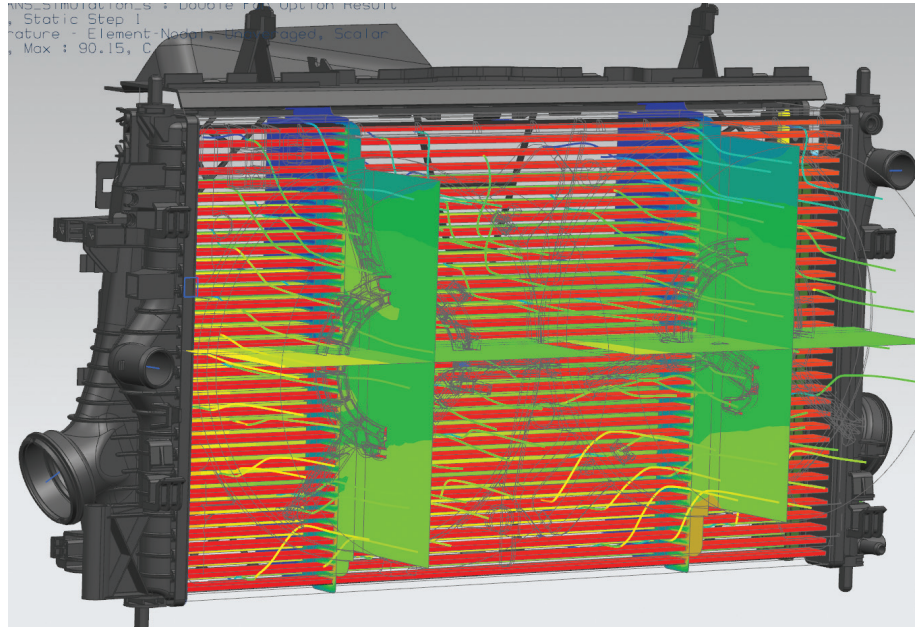

Hex mesh throughout central volume of geometry.

Supported hardware/OS

Simcenter 3D Advanced Thermal is an add-on module to either Simcenter 3D Engineering Desktop or Simcenter 3D Structures. It requires a license of Simcenter 3D Thermal as a prerequisite. All standard NX hardware/OS platforms are supported (including Windows, Linux and selected 64-bit platforms). Contact Siemens PLM Software with any other specific hardware/OS support requests.

Siemens PLM Software
www.siemens.com/plm

Americas +1 314 264 8499
 Europe +44 (0) 1276 413200
 AsiaPacific +852 2230 3308



844-GEO-SUPT
support@geoplms.com
geoplms.com

© 2017 Siemens Product Lifecycle Management Software Inc. Siemens and the Siemens logo are registered trademarks of Siemens AG. Simcenter is a trademark or registered trademark of Siemens Industry Software NV or any of its affiliates. Nastran is a registered trademark of the National Aeronautics and Space Administration. All other trademarks, registered trademarks or service marks belong to their respective holders.
 10623-A8 2/17 W