

NC programming with synchronous technology

SIEMENS



White Paper

Part model editing made easy for NC programmers

NC programmers often need to work with 3D model definitions for a variety of reasons. However, editing tasks can be difficult to perform as 3D part models frequently originate from multiple sources. This white paper describes the latest part model editing capabilities that are available through Siemens PLM Software's synchronous technology. It also explains how NC programmers can leverage these capabilities to more effectively resolve today's CAD model editing challenge.

Contents

Executive summary	3
CAD model editing and the NC programmer	4
Why manufacturing engineers edit 3D part models.....	5
Fixing model errors, inconsistencies and translation errors	5
Stage models or casting model preparation	5
Creating new 3D geometry from the part model	5
Handling design changes.....	5
Why most current options don't satisfy the NC programmer's model editing needs.....	6
Working with parametric models – a tricky tangle	6
Using direct modeling techniques: is basic modeling the answer?	6
Synchronous technology's revolution in model editing	7
No need to understand construction history	7
A new way to work with model geometry	8
Adding driving dimensions without complications.....	9
A record for tracking.....	9
Conclusion.....	10

Executive summary

NC programmers constantly work with 3D model-based part definitions to prepare them for manufacturing. In many instances, these 3D part models come from a variety of sources, especially if the shop is preparing contract jobs for a wide range of customers. The quality of 3D data varies enormously. In some cases, a finished design model is not exactly what the NC programmer needs for efficient, accurate NC program generation. A blend radius may need to be changed, or a draft angle added – but these seemingly simple tasks can lead to a frustrating modeling experience with wasted hours consumed by non-productive CAD work. Being able to work easily and without limitations on a 3D model, regardless of source or the design methods, can be a great time saver.

This white paper describes the latest CAD model editing capabilities available from Siemens PLM Software's synchronous technology and how these enhancements go a long way to solving the CAD model editing challenge for the NC programmer.

CAD model editing and the NC programmer

Manufacturing engineers face several challenges in the use of their CAD models for NC programming. NC programmers have many reasons for editing or adjusting the 3D part models that provide the basis for developing NC tool paths. This may have nothing to do with altering the part in terms of its form, fit or function. Rather, it might be something simple like adjusting the 3D model to close off open holes to present a clean and continuous surface for a machining sequence prior to making the holes. This may sound easy but this task can present time-consuming challenges for an NC programmer. From importing the model to getting the best model for machining, manufacturing engineers constantly work at a disadvantage for the simple reason that they are not the authors of the CAD model.

Manufacturing engineers, and NC programmers in particular, are often separated from the source of their CAD models by a combination of time, distance, translation, and even language. Even in tightly integrated operations, the author of the CAD model likely resides in a different department, different facility or even a different city. On average, it is much more likely that the author of a CAD model that makes its way to the NC shop is from a different company, or possibly from the other side of the world.

This means that manufacturing engineers are almost never well acquainted with the CAD models they use. They often need to ask questions that help them work with the CAD model or request changes from the author. With the pressures of responding quickly to the customer, manufacturing engineers need to complete their production tasks with a minimum of communication cycles with the CAD author.

Typically NC programmers are not CAD designers, nor do they necessarily know how the part was modeled. They see a 3D part in terms of geometry that needs to be changed to support more efficient programming and machining. They simply want to make that change at will, without the model falling apart or “failing to regenerate” or incurring some other similar obstruction.

A system that allows the NC programmer to make needed changes to the 3D geometry using intuitive, simple “grab and move” style commands can be a fantastic aid and time saver.

Why manufacturing engineers edit 3D part models

There are many reasons why an NC programmer needs to work with, and sometimes edit, 3D part model geometry. This white paper will consider just a few of these reasons.

Fixing model errors, inconsistencies and translation errors

If the part file came from another CAD system and has gone through some form of data conversion, things can go wrong. The latter situation happens even without data translations since 3D models that look perfect can be a mathematical mess underneath. Surfaces may be incomplete or miniscule mathematical gaps can arise between surfaces. These problems can be just enough to throw off many CAM processors. NC programmers may need to fix these “translation” errors before they start NC program preparation.

Most CAM systems will use the mathematics of the 3D part model surfaces to drive tool path directions. Even minor changes in surface mathematics between adjacent surfaces “patches” can lead to glitches in the final machined surface if they are not fixed. Without changing the part shape, the NC programmer may be forced to adjust or redefine the intended surface before tool paths can be added.

Stage models or casting model preparation

The final part model is what the CAD designer will nearly always deliver to manufacturing. In many cases, this needs substantial changes to turn the part model into a casting model or a model that might be used in mold tool design. For a casting model, nearly all dimensions will need to be altered, holes blanked off, ribs thickened and so on. Stage models can be elaborate versions of the part representing key stages of the manufacturing process. Some companies create these by using edited versions of the final part model.

In any case, it can be advantageous for the NC programmer to “close off” open holes and drillings so that prior surface machining can be driven over continuous, uninterrupted geometry. Another reason to do this might be instances where certain features will be created by EDM sinking after initial machining. For holes or pockets that pierce a complex surface, this “refilling” of the hole can be a really tough 3D modeling challenge for NC programmers, especially if the surface really needs to match the surrounding areas.

Adjusting fillet or blend radii is a classic requirement for the NC programmer. Often, the manufacturing engineer is given the option of adding or adjusting fillets to suit the optimum manufacturing scenario or method – such as the use of preferred tooling.

Creating new 3D geometry from the part model

There are lots of opportunities to create special objects derived from the basic part geometry. Soft jaws for a lathe chuck or custom fixturing components are typical examples. A basic stock model is similar to the concept of the casting model mentioned above. Each of these examples illustrates situations where the manufacturing engineer or NC programmer needs to use basic model tools and work with, or from, the source part model.

Handling design changes

One of the most frequent reasons for editing a part model involves late or detail design changes. NC programmers are frequently faced with a need to move a face, alter a draft angle, increase a hole diameter or react to an endless variety of design changes. Once the NC programming is started, it is much easier to edit the underlying 3D model rather than start over on a new 3D part file from the designer.

Why most current options don't satisfy the NC programmer's model editing needs

Working with parametric models – a tricky tangle

Many 3D design models are built using advanced construction methods, such as parametric modeling. In the hands of the designer, rapid changes and edits can look easy and fast. Importing a solid part with an accompanying model construction history, such as a parametric definition, seems like it would be ideal for the NC programmer who needs to adjust the geometry. Any changes to the model could be made by driving the model parametrics.

The first hurdle of parametric modeling systems for the manufacturing engineer is the requirement to use the same modeling system as CAD model author. CAD models with construction history can be rolled back and modified at the individual feature construction level, but only with the same CAD system that authored the model. This severely limits the ability of manufacturing engineers to perform these kinds of edits at every level. Even if the required CAD system is available to undertake feature-level edits, the resulting modified model still has to be transferred to the CAM system for subsequent work.

In addition, practice has shown that these models are difficult to modify. The strength of the parametric approach is the tightly constrained nature of the model, which preserves design intent and forces one dimension to depend on another. But these constraints are also the weakness of the parametric approach. In fact, the design authors of parts with several dozen features often struggle to make successful changes, even though they are familiar with each construction step. The manufacturing engineer, who had no hand in the model's original 3D construction, may take hours trying to make the model edits needed for NC programming – and still be unsuccessful. It might even be easier to remodel the part, or an area of the part, from scratch, wasting time and risking further errors.

Using direct modeling techniques: is basic modeling the answer?

History-free or explicit modeling solutions provide another modeling technique. Explicit modeling solutions are valuable because they are not dependent on any model construction method, or history, that was used to create the 3D part model.

However, two problems arise with this approach. Even if the initial data translation did not already convert the model to a dumb 3D shape with no record of how it was created or edited for future checking, the level of direct model editing by the NC programmer will also leave no obvious track in the model data about what changes were made. Process control and a need to meet tolerances and quality targets require that manufacturers maintain a full understanding and accountability of all model edits.

The second issue with direct or basic 3D geometry model editing techniques is the difficulty in handling even simple tasks. "Just moving that boss" or "changing that draft angle" may take hours of dragging and extruding, effectively requiring the NC programmer to remodel that area of the part. In other words, it takes a lot of time and 3D modeling skill to get just what's needed for manufacture without changing other key aspects of the design geometry.

Synchronous technology's revolution in model editing

When Siemens PLM Software introduced synchronous technology in 2008, its value for fast, easy model editing immediately became apparent. Synchronous technology provides a model editing process that does not depend on model construction history. Its unprecedented level of intelligence allows users to make edits in and around complex 3D geometry. It can be used with the basic, nonintelligent 3D shapes that often come from data translations. Synchronous technology can even be used with 3D models that have an intact and active model creation history, such as advanced parametric models, without destroying the history of how these models were created in the first place. This capability provides great value to the manufacturing engineer who is not the author of a part and is not intimately familiar with a part's construction. Even so, edits can be reviewed and accounted for, meeting the needs for process control in the manufacturing environment.

No need to understand construction history

Synchronous technology is a unique and powerful modeling approach that supports both planned and unplanned changes. It does not need to repeatedly rebuild the modeling sequence for each edit. In addition, dependencies between features are eliminated. This avoids the possibility of long sequences of update failures when one model change impacts the next feature and the next in the construction history.

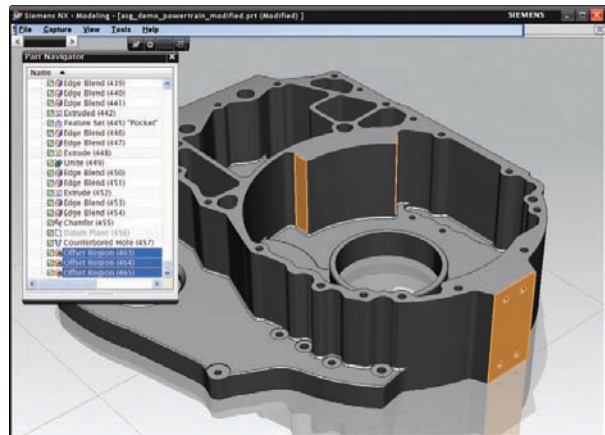
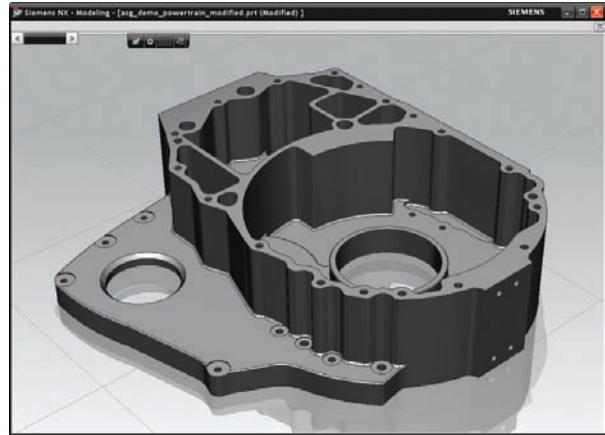

Synchronous technology lets users perform edits easily, without interference from feature construction histories.

A new way to work with model geometry

Synchronous technology examines surface topology, meaning the connection between one surface and its neighbors, to understand local features for modification. It can do this on just about any type of geometry, providing an important advantage for the manufacturing engineer.

The features recognized are not necessarily construction features, as found in a model construction record or “history tree.” Rather they are more likely to be the obvious features that the system sees the user directly manipulating. The user guides the “feature discovery” by specifying related face selections, such as coplanar or concentric, and has the final authority on which faces are selected and how the edits take place.

In many cases, strong geometric relationships (such as tangent, concentric, horizontal/vertical relationships) should never be “broken.” Synchronous technology recognizes these conditions and preserves them during edits – even if those conditions were never defined or were lost during translation. This capability becomes particularly important when making changes in the CAM system (but rules defined in CAD must be adhered to).

The result is an extraordinary capability to grab and adjust connected geometry elements (even entire sections of a model that are connected) and make edits that make sense, just with one command.

The NC programmer is no longer faced with a poor choice: either trying to adjust the parameters that the designer left on the model, or fiddling with each individual geometry element using basic model editing methods. Both approaches have drawbacks as outlined above, and remodeling from scratch can take hours, or even days. With synchronous technology, the NC programmer can make changes to a 3D model that even a super CAD user couldn’t do before without having built exactly that area of variability into the model from the outset.

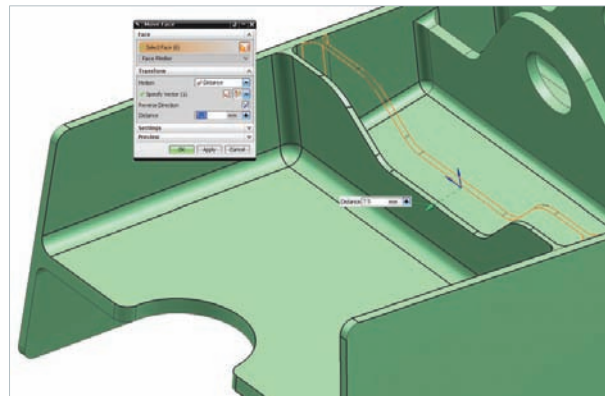
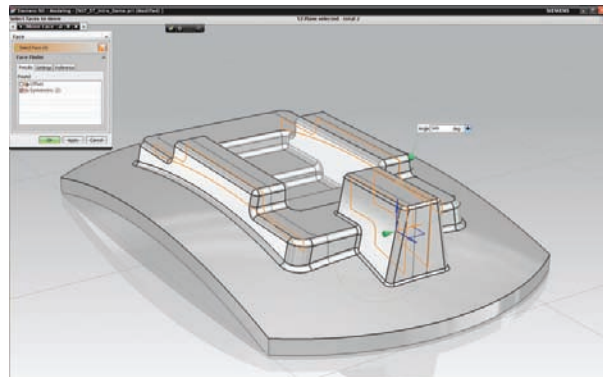

Synchronous technology has a very intuitive approach to features that lets manufacturing engineers work with the features that make sense to them.

Adding driving dimensions without complications

Synchronous modeling has the added power of dimension-driven editing, and even constraint application to maintain the intent of an edit. But these elements don't cause problems by interacting with the restrictive constraints held in the model's history tree. With the power of synchronous technology, the user can be freed from the limitations of previous constraints, yet can add driving dimensions and new constraints as needed to manage a new edit in the manufacturing, NC programming, casting or tooling model.

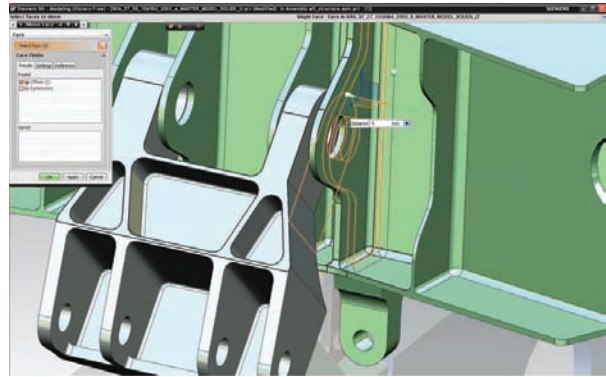

A record for tracking

The process benefits of recorded model history still are available to synchronous technology users, since each synchronous modeling edit can be saved for accountability, or even for later modifications. This capability provides the best of both worlds in terms of process control and direct, easy model editing.

Model edits made with the synchronous modeling approach can easily be saved as part of an edit sequence, taking the original model through several synchronous modeling steps to a new part configuration. Each synchronous edit can be independently activated or deactivated. The original part configuration can be reviewed by simply deactivating any edits. As a result, full accountability is maintained for process control.

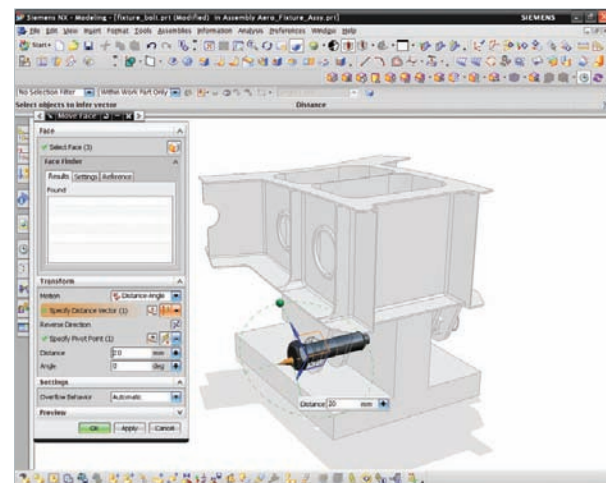

Synchronous technology quickly adapts assemblies and fixtures to accommodate new parts.

Conclusion

As indicated earlier, there are several scenarios where making model edits proves very useful in the NC environment. Starting with the basic need to clean up errors in imported geometry, there are a host of necessary and desired edits that the manufacturing engineer can undertake. Fillet and draft adjustments for better manufacturability and cost reduction can directly impact time and cost of production. Patching holes and other features for milling processes can allow better tool path development, and even higher quality surface finish. Casting models can be quickly developed. Soft jaws and custom fixture components can be derived from part faces. In addition, the ability

to re-use previous setups, fixtures and other components is enhanced with the unique synchronous modeling approaches.

Siemens PLM Software's NX™ CAM and CAM Express solutions are the only CAM systems that include synchronous technology with its unique, powerful approach to making model edits on all kinds of geometry. Models from any source, regardless of how they were constructed, can be edited and adjusted as needed with fast, simple geometry selections and new dimensions.

About Siemens PLM Software

Siemens PLM Software, a business unit of the Siemens Industry Automation Division, is a leading global provider of product lifecycle management (PLM) software and services with 6.7 million licensed seats and more than 69,500 customers worldwide. Headquartered in Plano, Texas, Siemens PLM Software works collaboratively with companies to deliver open solutions that help them turn more ideas into successful products. For more information on Siemens PLM Software products and services, visit www.siemens.com/plm.

www.siemens.com/plm

All rights reserved. Siemens and the Siemens logo are registered trademarks of Siemens AG. D-Cubed, Femap, Geolus, GO PLM, I-deas, Insight, JT, NX, Parasolid, Solid Edge, Teamcenter, Tecnomatix and Velocity Series are trademarks or registered trademarks of Siemens Product Lifecycle Management Software Inc. or its subsidiaries in the United States and in other countries. All other logos, trademarks, registered trademarks or service marks used herein are the property of their respective holders.

© 2011 Siemens Product Lifecycle Management Software Inc.

X3 20180 6/11 C



844-GEO-SUPT
support@geoplms.com
geoplms.com

Siemens Industry Software

Headquarters

Granite Park One
5800 Granite Parkway
Suite 600
Plano, TX 75024
USA
972 987 3000
Fax 972 987 3398

Americas

Granite Park One
5800 Granite Parkway
Suite 600
Plano, TX 75024
USA
1 800 498 5351
Fax 972 987 3398

Europe

3 Knoll Road
Camberley
Surrey GU15 3SY
United Kingdom
+44 (0) 1276 702000
Fax +44 (0) 1276 702130

Asia-Pacific

Suites 6804-8, 68/F
Central Plaza
18 Harbour Road
WanChai
Hong Kong
852 2230 3333
Fax 852 2230 3210