



Siemens PLM Software

Teamcenter integration for Solid Edge

Capture, manage and share Solid Edge data using Teamcenter, the de facto standard for PLM deployment

Benefits

- Integrate all of your technical data to provide a single source of product information that supports your complete design-through-manufacturing process
- Spend less time finding the correct revisions of your Solid Edge data
- Accelerate your product change and approval processes, reducing time-to-market
- Facilitate consistent work processes across all data formats, reducing errors and rework
- Improve collaboration within your organization and with customers and suppliers

Summary

The Teamcenter® integration for Solid Edge® (Solid Edge Embedded Client) allows you to reduce your product development cycle times and costs by enhancing your Solid Edge environment to provide a single source of product data for your design and manufacturing teams. The integration provides access to a full range of product lifecycle management (PLM) capabilities to further optimize your design-through-manufacturing processes.

Streamlined product development

The Teamcenter integration for Solid Edge® enables you to reduce product development cycle times and costs by seamlessly connecting Solid Edge to Siemens PLM Software's Teamcenter® platform, including Teamcenter Rapid Start. You can easily capture Solid Edge data for re-use in future projects without placing an additional burden on the designer.

Capture, manage and share Solid Edge data using Teamcenter

The Solid Edge Embedded Client enables design information created in Solid Edge to be captured, controlled and shared in a single, highly secure PLM environment. Comprehensive version management and access control capabilities ensure that the right people in your enterprise get the right information at the right time.

Using the Solid Edge Embedded Client, design teams can quickly search and access Solid Edge parts, assemblies and drawings eliminating time wasted trying to find and share design information. It also ensures that everyone in the design team is working from the latest design information.

The Solid Edge Embedded Client capabilities go beyond workgroup CAD data management, enabling design and manufacturing teams to work closely together to streamline product development and manufacturing delivery processes utilizing

Teamcenter integration for Solid Edge

Features

- Access Teamcenter and Teamcenter Rapid Start capabilities directly from Solid Edge
- Create and edit Solid Edge parts, drawings and assemblies under Teamcenter control
- Create and manage new revisions and versions of Solid Edge parts, drawings and assemblies
- Automatically create lightweight JT visualization files for Solid Edge parts
- Synchronize Solid Edge document properties with Teamcenter attributes
- Facilitate integrated product structure management
- Leverage synchronized releases of Solid Edge and the Solid Edge Embedded Client to ensure that Teamcenter users can quickly move to the latest Solid Edge release

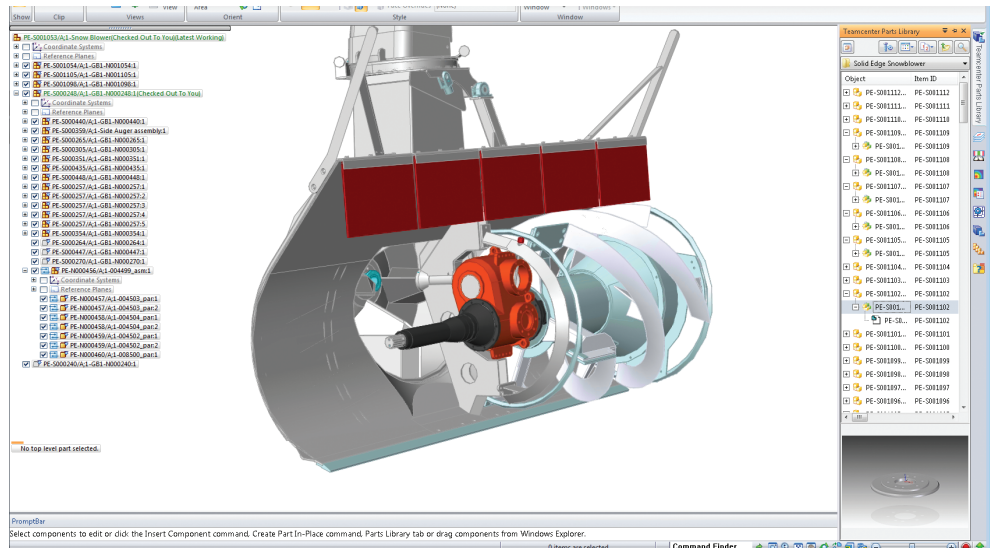

Access Teamcenter or Teamcenter Rapid Start from Solid Edge and leverage their workspace and other functions, including search and retrieve, graphical previews, where-used and check-in/check-out capabilities.

a single source of product data. The integration is optimized for scalability across a wide area network, enabling geographically distributed design resources and the extended supply chain to connect to a single database.

Transparent user interface and synchronized releases

The Solid Edge Embedded Client provides seamless and transparent connectivity between Solid Edge and Teamcenter:

- Solid Edge dialogs that handle file operations, such as the File Open dialog, are enabled to directly browse Teamcenter. Solid Edge documents are automatically filtered and displayed using Teamcenter attributes such as Item ID. An alternative bill of materials (BOM) view conveniently lists file dependencies within an assembly, as well as the relationships between the parts or assemblies and their associated drawings.

- The Solid Edge Pathfinder can display key attributes from Teamcenter, and you can access a menu of available Teamcenter operations by right clicking on the Solid Edge documents displayed.

Quickly find and open the correct version of your design data.

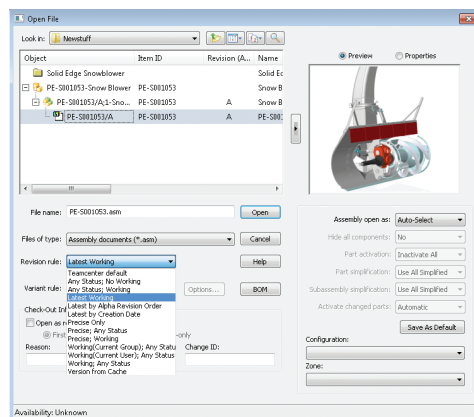

Supported Solid Edge documents include:

- Legacy weldments (.pwd)
- Assemblies (.asm, .cfg)
- Parts (.prt)
- Drawings (.dft)
- Sheet metal (.psm)

Supported functions

- Access Teamcenter from Solid Edge or Teamcenter Rapid Start and leverage their workspace and other functions, including search and retrieve, graphical previews, where-used, and check-in/check-out capabilities
- Save new documents to Teamcenter using business object rules for ID and revision
- Synchronize Solid Edge document properties with Teamcenter attributes
- Establish revision control for Solid Edge parts, assemblies and drawings and the associated design change and release processes
- Open Solid Edge documents with Teamcenter revision rules
- Copy and revise assemblies using the Solid Edge Structure Editor
- Determine check in/check out status and ownership of the parts in a Solid Edge assembly
- Search for and place components in a Solid Edge assembly
- Automatically generate and manage lightweight visualization (JT™) files for Solid Edge part models
- Capture non-Solid Edge documents linked to Solid Edge files (Microsoft Word and Excel, images)
- Use the Add to Teamcenter capability to bulk-load existing Solid Edge data
- Automatically capture Solid Edge assembly structures to build the Teamcenter product structure, then synchronize the two structures to capture any changes
- Manage links between Solid Edge parts and assemblies to their drawings, and to other referenced files
- Leverage Teamcenter FMS and SOA architecture for optimized performance in LAN and WAN environments

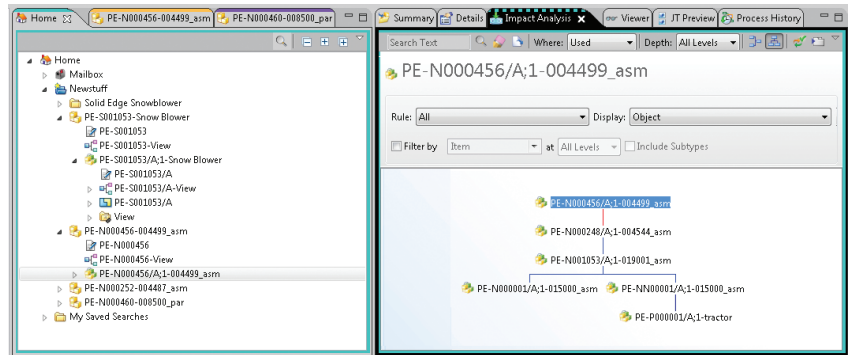

Intelligently assess the impact of changes on requirements, or other parts of the design.

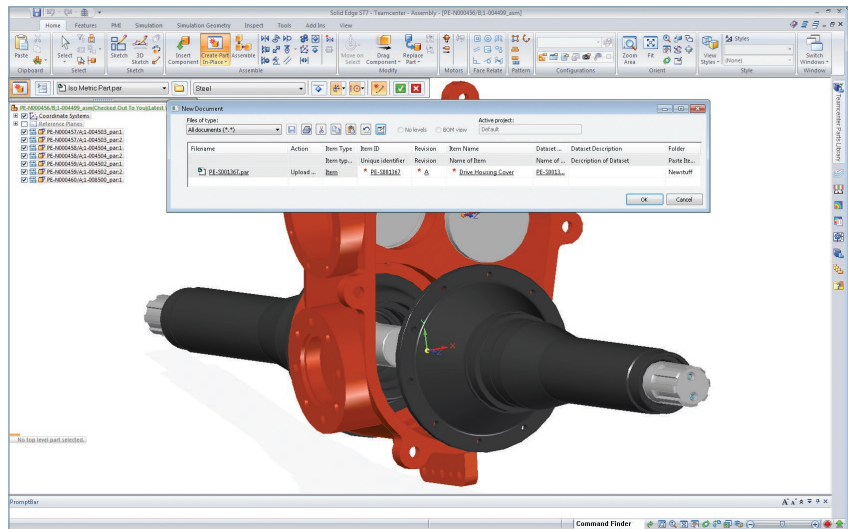

Dialog driven user interface makes it easy to save and manage design documents.

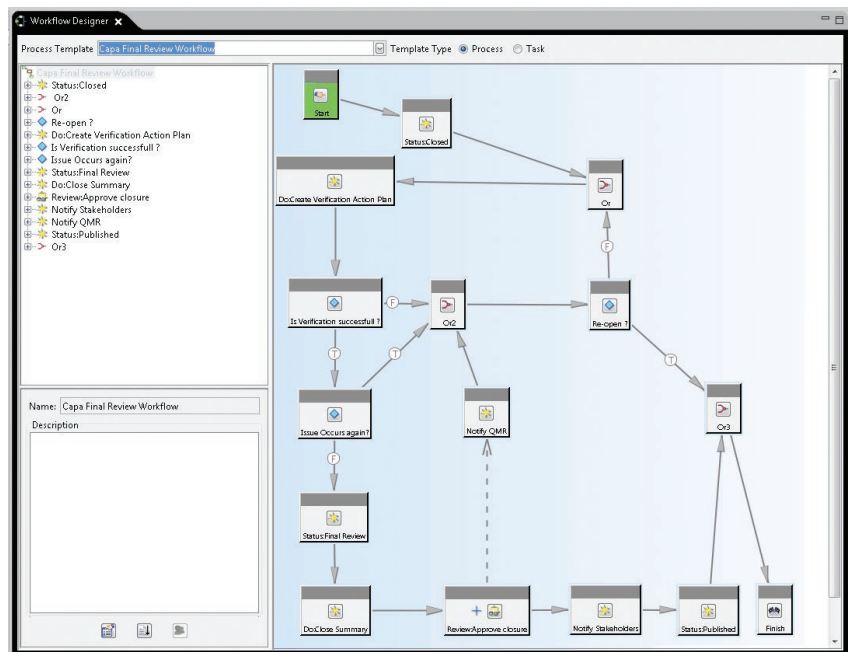

Leverage structured workflows and change processes.

Teamcenter advantage

The integration using the Solid Edge Embedded Client is supported by both Teamcenter and Teamcenter Rapid Start, which power innovation and productivity by connecting people and processes with knowledge.

- Teamcenter is the de facto standard for PLM deployments and is backed by Siemens PLM Software's leadership in delivery. Users of Teamcenter can easily expand the scope of their PLM implementation by taking advantage of a comprehensive portfolio of applications as well as its proven scalability in terms of performance and global implementation.
- Teamcenter Rapid Start is a preconfigured deployment option for Teamcenter that manages design data, as well as everyday tasks and processes, providing an ideal entry point into the Teamcenter product line for small and medium-sized businesses.

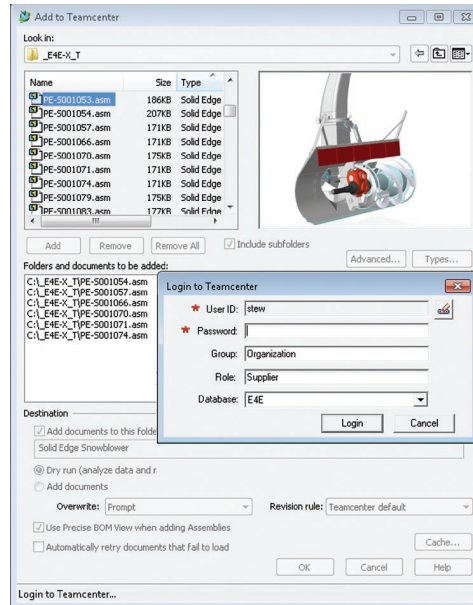

Bulk import existing Solid Edge designs using Add to Teamcenter utility.

Contact

Siemens PLM Software
 Americas +1 314 264 8499
 Europe +44 (0) 1276 413200
 Asia-Pacific +852 2230 3308

www.siemens.com/plm

© 2014 Siemens Product Lifecycle Management Software Inc. Siemens and the Siemens logo are registered trademarks of Siemens AG. D-Cubed, Femap, Fibersim, Geolus, GO PLM, I-deas, JT, NX, Parasolid, Solid Edge, Syncrofit, Teamcenter and Tecnomatix are trademarks or registered trademarks of Siemens Product Lifecycle Management Software Inc. or its subsidiaries in the United States and in other countries. All other logos, trademarks, registered trademarks or service marks belong to their respective holders.
 6106-Y3 9/14 C