

**SIEMENS**  
*Ingenuity for life*

# NX CAM Robotics Programming

## Plan, validate and optimize machining processes driven by robots

### Benefits

- Quickly create complex motion programs
- Validate programs graphically for faster startups
- Easily provide production-ready output
- React quickly to change orders with associative motion paths
- Eliminate translation steps and reduce IT costs with a single platform
- Set your own robotics rules to maintain flexibility
- Streamline programming with process automation at all levels

### Summary

The use of robots is expanding rapidly in a variety of manufacturing industries. Two trends are driving this change: recent improvements in accuracy, repeatability and payload capacity make robots adequate for increasing the number of machining tasks, and it is harder to find qualified workers that are willing to perform repetitive actions in tough environmental and physical conditions for a long time.

Beyond the familiar tasks of lifting, positioning and welding, today's robots are being fitted with milling, grinding and other heads so they can be used to deburr, grind, cut, trim, polish, finish, glue and more. These tasks require the robots to perform continuous precision motions, including area coverage patterns and removal of in-process material. It can be challenging to program this type of motion for robots using a manual approach or some of the existing software tools. Siemens PLM Software has integrated its proven Tecnomatix® software for advanced robotic solutions with NX CAM software to provide the NX CAM Robotics

Programming solution. This makes it easy to program a robot to cut, trim, finish, etc., using familiar NX CAM computer numerical control (CNC) programming methods.

NX CAM Robotics software lets you design, simulate, validate, optimize and offline program your industrial robots for machining-type tasks. This solution greatly increases the efficiency and quality of these high-precision, multi-axis robotic operations. Featuring the intuitive and widely-accepted NX™ software 3D environment, the software combines the simplicity of CNC programming with the power to accurately create, control and simulate complex robotic machining processes.

Associative updates, a key benefit of the entire NX system, make it easy to accommodate change orders since the robotic programming can be refreshed when design changes occur.

### Robot definition

The NX CAM Machine Tool Builder now enables you to define robotic kinematic chains, making it easy to incorporate robots as the CNC machine selection in NX CAM. This is the basis for simulating the robot's motion as well as providing the correct output for the controller.

Commonly-used robot models are provided with the NX CAM library of example machines, and are easily customized with the NX CAM Machine Tool Builder.

### Toolpath to robotic path

The concept behind NX CAM Robotics Programming is to use the robust

# NX CAM Robotics Programming

## Features

- Supports robots from many vendors
- Articulated six-axis robot with support for external axes, such as positioner and rails
- 3D kinematic assembly modeling to define heads, holders, positioners, rails and other robotic peripherals
- Static and dynamic analysis of collisions, reachability and singularities
- Robotics rules control tool orientation, robot configuration, start and end poses, robot motion along rail and positioner behavior and OLP commands
- A single intuitive look and feel for NX CAD, NX CAM and NX CAM Robotics Programming
- Process automation templates help you create paths and apply rules quickly

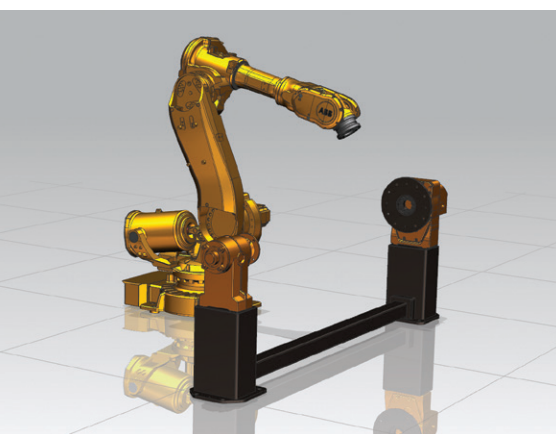
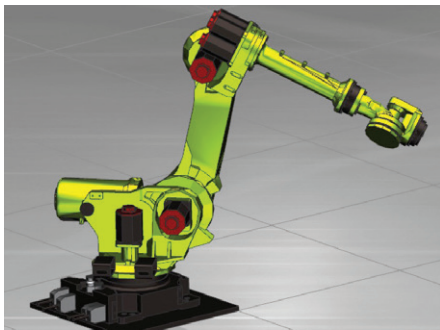

toolpath creation methods of NX CAM to generate the end effector motion. This motion enables you to make sure the cutter or grinder moves along the workpiece in whatever pattern is required. In addition to this basic path are robotic rules that account for the extra degrees of freedom (axes of motion) and possible singularities. The user specifies preferences with straight-forward rules for aligning the head relative to the working path, such as fixed vector, tangent to path and tangent zigzag. The configuration of the robot provides additional rules that help guide its motion and maintain predictable orientations along the motion and the starting and ending poses.

## Advanced robot setups

One of the great benefits of using robots for machining is the large work envelopes they can cover and the flexibility they can apply to reach inaccessible areas.

In order to support machining of complex shapes with difficult reaches, a part positioner is often used. NX CAM Robotics Programming supports these use cases by synchronizing the robot with the positioner and controlling its motion pattern. A positioner can rotate to a constant angle and maintain that angle along the entire process, or rotate continuously to keep the tool angle throughout the process.

When a large or long part is being machined, a robot might move along a

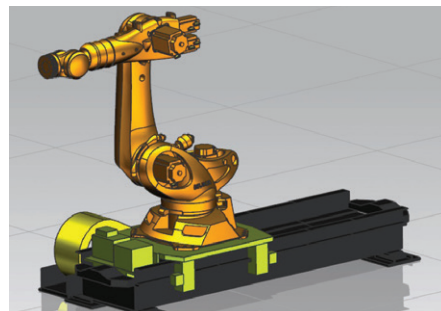

rail to increase its work envelope even further with this additional axis. NX CAM Robotics allows the robot to move along the rail to a specific position from where it can reach the entire toolpath, or continuously move back and forth to ensure all locations can be reached.

## Robotic path validation

The complete, proven suite of NX CAM validation tools is available for robotics path validation. Material removal verification can be displayed during machine simulation. Collision detection and gouge checking are available to identify any interference issues between the robot, its tool, the fixture and the part. Reachability issues, such as inaccessible locations along the path and robot joints that exceed their hard or soft limits, are reported and can be analyzed. Special robotic issues, such as kinematic singularities, can also be automatically identified and reported.

Robot tool traces can be displayed during simulation to provide another important view of the motion. These advanced validation tools ensure high-quality programs that can be reliably executed by robots, reducing prove-out times and minimizing production issues.

## Offline programming

With NX CAM Robotics Programming, the user can add offline programming (OLP) commands based on motion type in order to accurately follow company standards and ensure that the commands are properly considered even during part and process changes. OLP commands can be applied at various stages, including: start of the motion, end of the motion, the end of any approach move, the start of any departure move, the start of a traverse move, between machining regions, within regions and at the initial and final approach and depart moves. The system supports user interface (UI) customization so companies can create their own dialogs to easily input OLP commands and motion parameters without learning complex robot language syntax.

Six- and seven-axis robotic configurations can be defined and used in NX, including robots on rails and work positioners.

## Postprocessing

Production-ready output that does not require any manual modifications is the key to shortening planning cycle time and increasing productivity. The standard postprocessing mechanism of NX CAM generates the robotic program. Available posting modules for Kuka (KRL), ABB (Rapid), Fanuc (RJ TPE) and Siemens' Sinumerik 840D controllers can be used to generate standard programs on these common controllers. The new NX CAM Post Configurator enables you to adjust and fine-tune the posting process according to other requirements, company standards and preferences.

## Providing a common NX platform

With the integrated robotics programming in NX, you get the same benefits for assemblies and associativity as with other NX applications, such as computer-aided manufacturing (CAM). Programming the motion of the trimming, cutting or grinding tool can be accomplished using the same

user-friendly techniques that CAM programmers enjoy. And the toolpaths will update associatively to accommodate any design changes, too.

Standardizing on NX for computer-aided design (CAD), CAM and robotics programming simplifies your software purchasing, installation and training requirements. Supporting a single product platform from a market-leading vendor relieves stress for your information technology (IT) staff and reduces the number of interfaces.

## Fully managed environment

The NX CAM Robotics Programming solution can be fully managed with the Teamcenter® software data and process management system as part of the NX CAM family. Take full advantage of the managed environment to ensure you are producing the correct product revisions subject to the proper reviews with the latest tools and fixture definitions.

## CAN robots really replace CNC machining centers?

*CNC machining has long been the domain of specialized machine tools. Boring mills, vertical turret lathes (VTLs), five-axis trunnion tables and even Swiss-style lathes feature specialized configurations meant to ideally solve one subtype of NC machining challenge. This is done by maximizing structural efficiency for a particular tool application, but in every case the most limiting factor is the work envelope. It becomes expensive to scale up these machines to large envelope sizes because their specialized structure has to scale as well.*

*Robot cells are a much more affordable way to cover large, multi-axis work envelopes. For a host of relatively low-force machining functions, such as trimming and grinding, deburring, polishing, finishing, gluing, light cutting and more, it is easy to expand the work envelope using robot arms that can reach a long way and contort to match any required tool axis.*

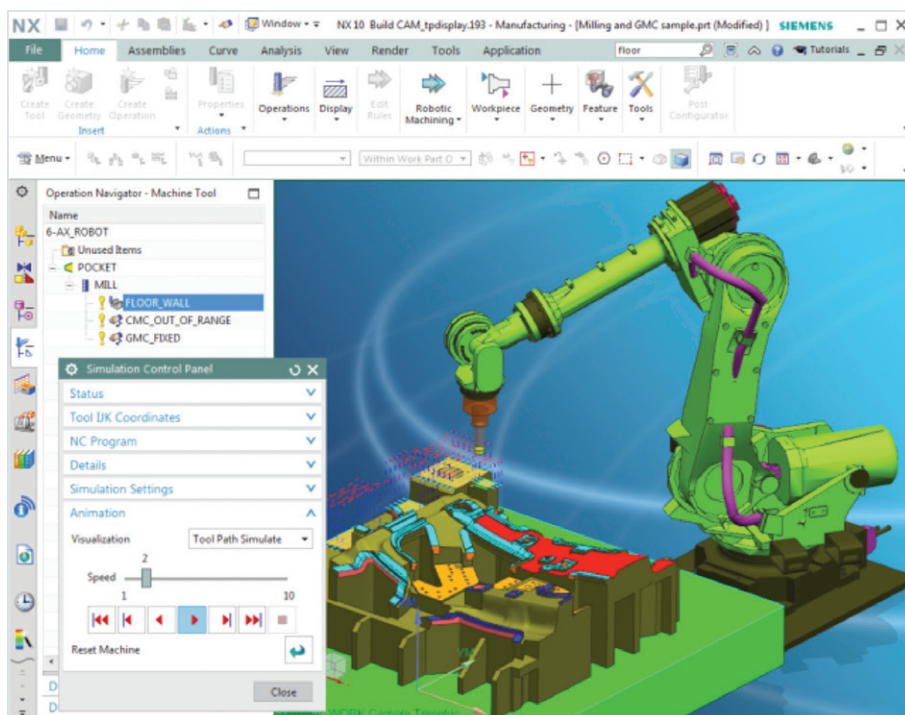

With NX CAM Robotics Programming, you can easily create cutting, trimming or grinding motions and simulate the robot as it performs the role of the machine tool.

Siemens PLM Software  
[www.siemens.com/plm](http://www.siemens.com/plm)

Americas +1 314 264 8499  
 Europe +44 (0) 1276 413200  
 Asia-Pacific +852 2230 3308

© 2016 Siemens Product Lifecycle Management Software Inc. Siemens and the Siemens logo are registered trademarks of Siemens AG. D-Cubed, Femap, Fibersim, Geolus, GO PLM, I-deas, JT, NX, Parasolid, Solid Edge, Syncrofit, Teamcenter and Tecnomatix are trademarks or registered trademarks of Siemens Product Lifecycle Management Software Inc. or its subsidiaries in the United States and in other countries. All other logos, trademarks, registered trademarks or service marks belong to their respective holders.

50716-A9 9/16 H