

Automotive and transportation

Robert Bosch

From spark plugs to adaptive cruise control

Products

NX, Teamcenter

Business challenges

Continuous innovation

Shorter time-to-market

Resource optimization

Keys to success

Grouping products into re-usable base models and versions

Use of WAVE technology

More than 20 database servers all over the world

Results

Faster generation of new product models

Cost savings

Higher flexibility

Closer to customers

Global engineering network ensures Tier-1 supplier's continuous innovation

A tradition of innovation

For more than 70 years Robert Bosch GmbH has been a leading global automotive supplier. The Chassis Systems Control (CC) department develops and produces electronic brake control systems such as anti-lock brakes (ABS), traction control (ASR) and the electronic stability program (ESP). Of the approximately 17,000 employees, there is a high percentage of research and development positions.

At Bosch, performance, development, production, distribution, marketing, purchasing and customer service have been integrated into a tight global network aimed at achieving continuous innovation. To accomplish this, high-performance software tools and IT infrastructure are imperative, which is why the Chassis Systems Control department relies on the products and knowledge of its product lifecycle management (PLM) technology supplier, Siemens PLM Software.

"Our activities are based on efficient worldwide coordination and the communication of everyone involved in the development process," explains Dieter

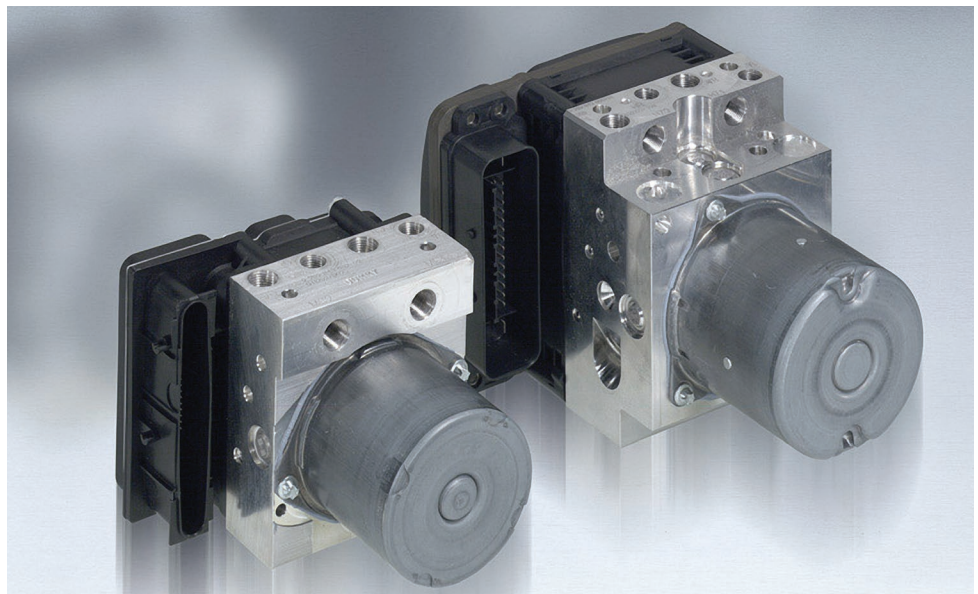

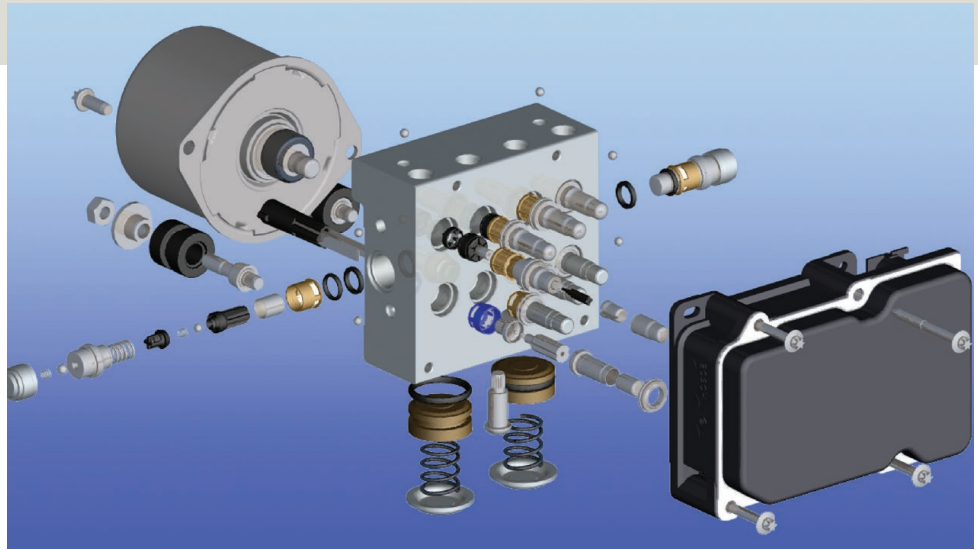

“We have come to recognize the multi-site solution of Teamcenter as a very good, high-performance tool. We value it as the best system available on the market for us.”

Michael Schlitzkus
Engineering Department
Bosch C.C.

Morio, manager of the CC division in the sector of technical IT, Bosch. “International teams work on a standardized process together with our customers from the automobile industry. System applications are carried onsite close to the customer. The same applies to production. We manufacture all over the world according to uniform production and quality standards. This ensures consistent high-quality products worldwide.”

The CC department uses NX™ design software for product development as well as Teamcenter® digital lifecycle management software for information management. The software solution runs on approximately 120 workstations in the department. Introduced in 1999, this solution was used for the development of the current ESP generation 8 (ESP8), among other things.

Global data pool

The current ESP was defined as modular from the beginning. Its purpose was to ensure that all basic models for the American, Asian and European markets could be re-used with minimal effort, to position new products on the market as quickly as possible. To achieve this, the CC department, together with the IT engineering support of Bosch, established a global data pool for worldwide development based on Teamcenter. From this collaboration, a software environment was developed that performs like a system.

A worldwide development team was formed to first define the base model and drawings for the ESP8 series. These were to be independently usable by each customer, from a motorcycle to a light-duty

Solutions/Services

NX
www.siemens.com/nx
Teamcenter
www.siemens.com/teamcenter

Customer's primary business

Robert Bosch GmbH is a leading global automotive supplier.
www.bosch.com

Customer location

Stuttgart
Germany

truck. Customer-specific requirements were supplemented during the distribution of base models to the individual markets. The uniform CAD base models with associated drawing sets for the ESP8 series were defined using NX. For example, they showed that a pump housing made of aluminum has different holes to fit different components. In this way it is possible, in theory, to make about 2,500 versions from six raw parts and 24 base parts. Since the basic structure of the ESP8 series was defined using NX WAVE technology, variations made with the customized additions and adjustments are always associatively linked, through so-called WAVE links, with the respective base model.

Based on this, efforts to generate new base models as well as the corresponding drawings have been significantly reduced. Generation of versions or their modifications can also be done faster. A database with worldwide access to current data was imperative for product development, according to the goal of implementing international simultaneous engineering.

Worldwide simultaneous engineering

The department established a PLM concept using Teamcenter with separate servers for individual regions and different time zones (where it worked with replicated data), to achieve optimum loading times at all locations. Data adjustments are required to more than 20 worldwide databases, most of which are Windows-based. The data adjustments are made at night for regionally limited simultaneous engineering environments. As night varies globally, Bosch decided to perform the automatic synchronization at the end of the working day of the affected time zone for a maximum delay of 24 hours. Furthermore, synchronization can be activated manually at any time. Bosch is also considering synchronization when a component is saved.

Bosch CC requires high performance, easy operation, low administration and low complexity for the simultaneous engineering environment. "We are a significant step closer to our goal using the Teamcenter solution that has just been installed," says Michael Schlitzkus, of the Bosch CC engineering department. "Furthermore, we can access the global data pool in which only one master record is present."

"We are a significant step closer to our goal using the Teamcenter solution..."

Michael Schlitzkus
Engineering Department
Bosch C.C.

Siemens PLM Software

Americas +1 314 264 8499
Europe +44 (0) 1276 413200
Asia-Pacific +852 2230 3308

www.siemens.com/plm

© 2015 Siemens Product Lifecycle Management Software Inc. Siemens and the Siemens logo are registered trademarks of Siemens AG. D-Cubed, Femap, Fibersim, Geolus, GO PLM, I-deas, JT, NX, Parasolid, Solid Edge, Syncrofit, Teamcenter and Tecnomatix are trademarks or registered trademarks of Siemens Product Lifecycle Management Software Inc. or its subsidiaries in the United States and in other countries. All other logos, trademarks, registered trademarks or service marks belong to their respective holders.
9366-27 1/15 C