

NX Sheet Metal Design

Accelerating design of sheet metal components of any complexity

Benefits

- Intuitive user interface results in reduced learning curve
- Streamlined workflow requires less time for part design

Features

- Built-in design intent using a focused sheet metal workflow
- Customer-defined default values
- Intuitive user interface
- Built-in intelligence for ripping and bend relief

NX delivers a tailored environment for sheet metal design, with onscreen controls and modeling commands for typical features in sheet metal components.

NX Sheet Metal Design includes tools for unfolding bends to create accurate flat patterns for fabrication.

Summary

NX™ software, the digital product development solution from Siemens, includes a set of state-of-the-art tools for designing sheet metal components. Using familiar terminology and workflows, NX Sheet Metal Design provides the design professional with a complete set of tools to efficiently create and manage sheet metal parts based on the knowledge of material properties and manufacturing processes. NX Sheet Metal Design tools incorporate material and bending information, enabling the model to represent both the formed component and flattened blank shapes.

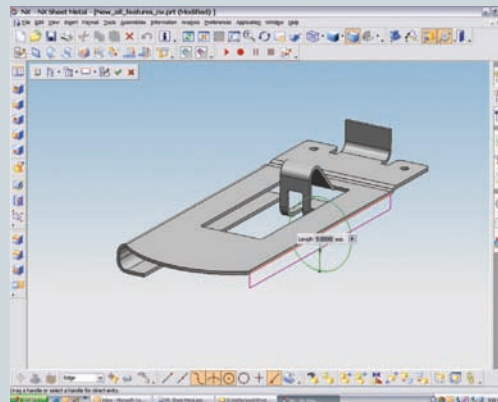

The sheet metal design tools within NX allow companies to apply defaults – based on both industry and company best practices – to the values used in the creation of sheet metal parts. For example, bend radii and neutral factor values can be set to commonly used values to encourage re-use and save design time.

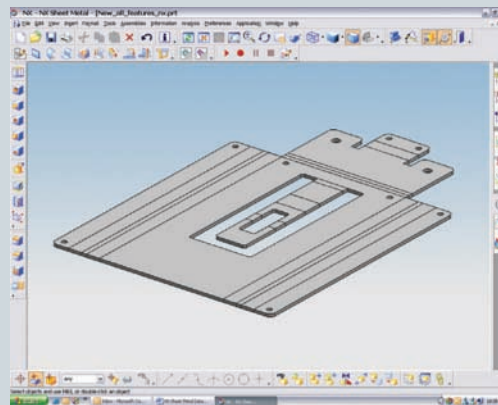

Folded and unfolded views of sheet metal components can be used in both the 3D environment as well as downstream in 2D documentation and for manufacturing.

NX

www.siemens.com/nx

SIEMENS

NX Sheet Metal Design

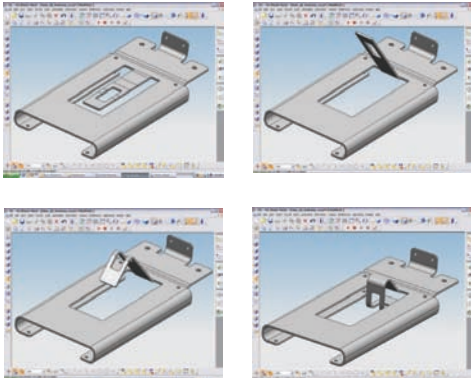

Features of the NX Sheet Metal Design solution include:

- A focused workflow tailored specifically to the design of sheet metal parts means the design intent is built in – the software automatically accommodates sheet metal production methods.
- Customer-defined values for thickness and bend radii enable designers to change materials, the thickness value and/or the neutral factor without re-creating the part model.
- An intuitive user interface allows designers to interact more directly with the model on the screen and less with dialog boxes. Less switching from mouse to keyboard saves design time.
- Built-in intelligence allows the system to automatically rip the material and apply bend reliefs as needed when features are added.
- The solution creates flat solid blanks of components that always reflect the current state of the 3D model.

- Allows forming from formed to flat, flat to formed and formed to formed
- Allows direct transmission between NX and Trumpf machines without need for general translators
- A complete set of bending features allows for the creation of flanges, bends and jogs that can all be unbent and rebent, as required. Also included is a new method to generate sheet metal parts from a solid which allows users to quickly design a sheet metal enclosure around it
- Robust flat pattern and capabilities for sheet metal validation, such as validating clearances for bending and punch tools, which aid in manufacturing processes

With a reduced learning curve and intuitive interface, NX Sheet Metal Design enables fast and efficient part design.

Advanced sheet metal

Advanced Sheet Metal Design tools are

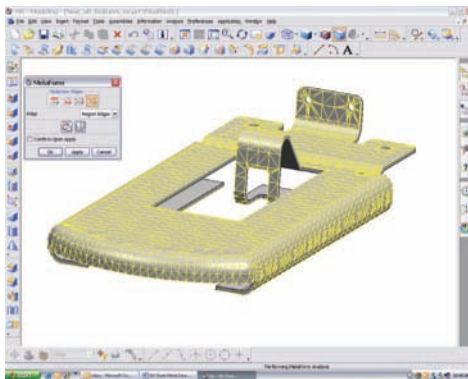

NX Advanced Sheet Metal Design includes powerful forming and flattening tools for complex shapes.

also available to aid in the design of complex sheet metal parts. Advanced sheet metal features include general flange and sheet metal bridge, which aid in the design of curved and nonplanar flanges. Also included are utilities for general flattening and forming of complex solid models, including sheet metal parts. These flattening/forming utilities include flat pattern, metaform and fabric flattening. Each uses unique algorithms to form a solid part from one state to another, or to generate a flat blank shape that can then be delivered to manufacturing.

Packaging and availability

NX straight-brake sheet metal design tools are included in all NX Mach Series solutions for design, styling and tooling, as well as in the Mach 3 and 4 NC machining products. The advanced sheet metal and fabric flattener tools are available as an add-on package for NX Mach Series solutions.

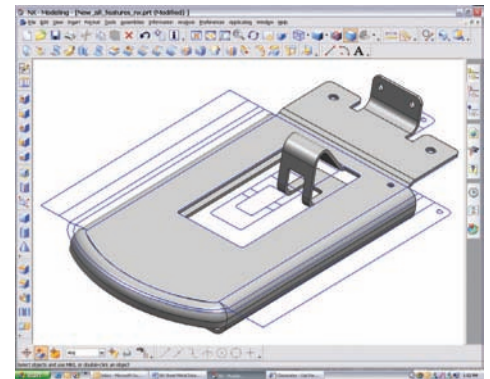

Contact
Siemens Industry Software
Americas 1 800 498 5351
Europe +44 (0) 1276 702000
Asia-Pacific 852 2230 3333

www.siemens.com/nx

© 2011 Siemens Product Lifecycle Management Software Inc. All rights reserved. Siemens and the Siemens logo are registered trademarks of Siemens AG. D-Cubed, Femap, Geolus, GO PLM, I-deas, Insight, JT, NX, Parasolid, Solid Edge, Teamcenter, Tecnomatix and Velocity Series are trademarks or registered trademarks of Siemens Product Lifecycle Management Software Inc. or its subsidiaries in the United States and in other countries. All other logos, trademarks, registered trademarks or service marks used herein are the property of their respective holders.
X5 5031 6/11 B